

HERALD COMPACT 5 Wood Burning Stove

Installation and Operating Instructions

Herald Compact 5

Technical Specification

Appliance Mass	95 kg
Total Efficiency	76.0 %
Nominal Heat Output	4.5 kW
Mean CO Emission (@13% O₂)	0.30 %
Mean Flue Gas Temperature	269 °C
Flue Gas Mass Flow	4.7 g/s

This appliance is not for use in shared flue

This appliance is suitable for intermittent burning

General Guidance

It is important that your stove is correctly installed as Hunter Stoves cannot accept responsibility for any fault arising through incorrect use or installation.

These instructions cover the basic principles to ensure satisfactory installation of the stove, although detail may need slight modification to suit particular local site conditions.

The installation must comply with current Building Regulations, national and European standards, Local Authority byelaws and other specifications or regulations as they affect the installation of the stove.

The Building Regulations requirements may also be met by adopting the relevant recommendations in the current issues of British Standards BS 8303 and BS EN 15287-1.

Competent Persons Scheme

Hunter Stoves recommend that this stove is installed by a member of an accredited competent persons scheme e.g. HETAS.

If the installer is not a member of a competent person's scheme, it is a legal requirement to notify your local building control body in advance of any work starting.

CO Alarms

Building regulations require that whenever a new or replacement fixed solid fuel or wood/biomass appliance is installed in a dwelling, a carbon monoxide alarm must be fitted in the same room as the appliance.

Further guidance on the installation of the carbon monoxide alarm is available in BS EN 50292:2002 and from the alarm manufacturer's instructions.

Provision of an alarm must not be considered a substitute for either installing the appliance correctly or ensuring regular servicing and maintenance of the appliance and chimney system.

Health and Safety Precautions

Special care must be taken when installing the stove such that the requirements of the Health and Safety at Work Act are met.

Handling

Adequate facilities must be available for loading, unloading and site handling.

Fire Cement

Some types of fire cement are caustic and should not be allowed to come into contact with the skin. In case of contact, wash immediately with plenty of water.

Asbestos

This stove contains no asbestos. If there is a possibility of disturbing any asbestos in the course of installation then please seek specialist guidance and use appropriate protective equipment.

Metal Parts

When installing or servicing this stove, care should be taken to avoid the possibility of personal injury.

Modification

No unauthorized modification of this appliance should be carried out.

SAFETY

WARNING – This appliance will be hot when in operation and due care should be taken. The supplied operating tool or gloves may be used to open the door and operate the air controls.

Aerosols

Do not use an aerosol spray on or near the stove when it is alight.

Fireguards

Always use a fireguard in the presence of children, the elderly or the infirm. The fireguard should be manufactured in accordance with BS8423 – Fireguards for use with solid fuel appliances.

Do not Over-Fire

It is possible to fire the stove beyond its design capacity. This could damage the stove so watch for signs of over-firing.

If any part of the stove starts to glow red, the stove is in an over-fire situation and the controls should be adjusted accordingly.

Never leave the stove unattended for long periods without first adjusting the controls to a safe setting.

Careful air supply control should be exercised at all times.

Fume Emission

WARNING NOTE

Properly installed, operated and maintained, this appliance will not emit fumes into the dwelling. Occasional fumes from de-ashing and refuelling may occur. However, persistent fume emission is potentially dangerous and must not be tolerated.

If fume emission does persist, then the following immediate action should be taken: -

- ▶ Open doors and windows to ventilate the room and then leave the premises.
- ▶ Let the fire go out.
- ▶ Check for flue or chimney blockage and clean if required.
- ▶ Do not attempt to re-light the fire until the cause of the fume emission has been identified and corrected. If necessary, seek expert advice.

The most common cause of fume emission is flue way or chimney blockage. For your own safety these must be kept clean at all times.

Adverse Weather

In a small number of installations, occasional local weather conditions (e.g. wind from a particular direction) may cause draught in the flue and cause the stove to emit fumes.

In these circumstances, the stove should not be used. A professional flue installer will be able to

advise on solutions to this problem (e.g. anti-downdraught cowl).

Do not fit an extractor fan in the same room as this appliance.

CO Alarm

Your installer should have fitted a CO alarm in the same room as the appliance. If the alarm sounds unexpectedly, follow the instructions given under “Warning Note” in the Fume Emission section.

In the Event of a Chimney Fire

- ▶ Raise the alarm
- ▶ Call the Fire Brigade
- ▶ Close appliance air controls
- ▶ Move furniture, ornaments etc away
- ▶ Place a fireguard in front of stove
- ▶ Check the chimney breast for signs of excessive heat.

Ensure the Fire Brigade can gain access to your roof space in order to check for fire spread.

Assembly Instructions

FLUE COLLAR AND BLANKING PLATE

Wind the eight M6 studs supplied into the fixing holes in the flue collar and blanking plate until finger tight.

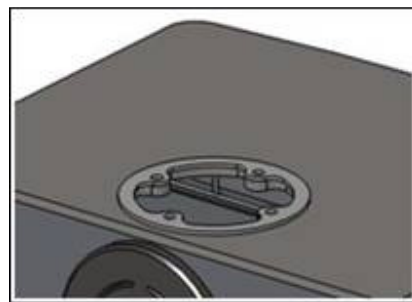

Place a flue outlet gasket in position on the top plate of the stove and lower the flue collar or blanking plate (as required) on to the stove top, taking care to line up the studs with the fixing holes.

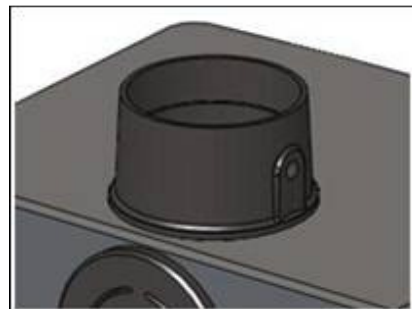

Secure in place using the M6 nuts and washers. Slide the remaining gasket on to the studs of the flue collar or blanking plate and secure in place on the back plate. Unless the optional flue damper is being fitted, blank off the damper handle holes in the flue collar using the two M8 coach bolts.

Installation Instructions

Chimney

The chimney height and the position of the chimney terminal should conform to Building Regulations.

Check that the chimney is in good condition, dry, free from cracks and obstructions.

The diameter of the flue should not be less than 150mm and not more than 200mm.

If any of these requirements are not met, the chimney should be lined by a suitable method.

If there is no existing chimney then either a prefabricated block chimney in accordance with Building Regulations Approved Document J, or a twin-walled insulated stainless steel flue to BS EN 1856 can be used. These chimneys must be fitted in accordance with the manufacturer's instructions and Building Regulations.

If the chimney is believed to have previously served an open fire installation, it is possible that the higher flue gas temperature from the stove may loosen deposits that were previously firmly adhered, with the consequent risk of flue blockage. It is therefore recommended that the chimney be swept a second time within a month of regular use after installation.

If you have any doubts about the suitability of your chimney, consult your local dealer/stockist.

Connection to the Chimney

The chimney must be swept before connection to the stove.

An existing fireplace opening can be bricked up or sealed with a register plate.

A short length of flue pipe of minimum 125mm internal diameter may then be used to connect the stove to the chimney. This flue pipe should be made of 316 grade stainless steel or vitreous enamelled steel, nominal thickness 1.2mm.

Ensure that the pipe end is no closer than 76mm to the chimney walls.

The length of any horizontal run of flue pipe must not exceed 125mm.

It is essential that all connections between the stove and chimney-flue are sealed and made airtight.

Both the chimney and flue pipe must be accessible for cleaning and if ANY part of the chimney cannot be reached through the stove (with baffle removed), a soot door must be fitted in a suitable position.

Flue Draught

If the draught exceeds the recommended maximum, a draught stabiliser must be fitted so that the rate of burning can be controlled and to prevent over firing.

If the reading is less than the recommended minimum then the performance of the appliance will be compromised.

The flue draught should be checked under fire at high output.

Minimum Draught – 1.2mm Water Gauge
Maximum Draught – 2.5mm Water Gauge

Air Supply

The room or space containing this appliance should have purpose provided ventilation (where necessary) in accordance with Building Regulations.

Due consideration should be given to air requirements for any other appliance in the same room or space.

Any air opening must be kept clear from blockage or obstruction.

Hearth/ Material Clearances

Your stove must be installed on a floor with adequate load-bearing capacity; otherwise suitable measures should be taken.

Use the adjusting screws in the feet to level the stove.

The stove can be recessed into a suitably sized fireplace. Ensure there is a free air gap of at least 150mm above and 50mm around the sides and rear of the stove.

Where possible it is recommended that a free air gap of 150mm or more is left around the sides of the stove to obtain maximum heat output and to gain access to the rear of the stove.

The stove should stand wholly above a solid, non-combustible hearth of at least 125 mm thickness, (this may include the thickness of a solid floor).

The hearth should extend at least 150 mm from the sides and rear of the stove, and at least 225 mm from the front of the stove.

JINHHC05WB RevA 27/04/12

All non-combustible walls closer than 300mm to the stove should be at least 75mm thick.

Minimum Distances to Combustible Material

Behind the stove	750mm
At the side of the stove	350mm
In front of the stove	900mm

Note: combustible material refers to any material that will degrade when subjected to heat e.g. plaster.

No combustible material must be stored underneath the stove.

Commissioning & Handover

Upon completion of the installation, allow a suitable period of time for any fire cement and mortar to dry out.

A small fire may then be lit and checked to ensure the smoke and fumes are taken from the stove up the chimney and emitted safely to atmosphere.

Do not run the stove at full output for at least 24 hours.

On completion of the installation and commissioning, ensure that the operating instructions and operating tools for the stove are left with the customer.

Advise the customer on the correct use of the appliance with the fuels likely to be used on the stove and warn them to use only the recommended fuels for the stove.

Advise the user on what to do should smoke or fumes be emitted from the stove. The user should be warned to use a fireguard to BS 8423 in the presence of children and/or infirm persons.

Operating Instructions

This appliance is **not** suitable for use in a shared flue.

Operation with the door open can cause excess smoke. This appliance must **not** be operated with the door open.

Aerosol Sprays

Do not use an aerosol spray on or near the stove when it is alight.

Air Controls

This stove has been designed to burn far more efficiently than a traditional stove, with the obvious notable feature of clean glass.

However, for this product to work properly it must be used correctly. To prevent excess smoke emissions, the air controls of this appliance must only be operated as directed in the instructions.

It is essential that the stove has an adequate air supply for combustion and ventilation.

Primary Air

Primary air is controlled via the slider in the door. The amount of air can be increased by moving the slider to the right. On the double door versions the amount of air is increased by moving the sliders outwards.

This provides a conventional air draught to the bed of the fire.

Secondary Air

Secondary air is controlled via the slider above the door; it is this “Airwash” that keeps a clean and uninterrupted view of the fire. The amount of air can be increased by moving the slider to the right.

Tertiary Air

Tertiary air aids in good secondary combustion of the fuel and reducing emissions into the chimney and environment.

Tertiary air can be controlled by adjusting the cover plate on the back of the stove.

Warning! - This Appliance will be hot when in operation and due care should be taken.

We advise that suitable gloves are used when operating the Primary and Secondary air controls, and when opening the door.

Notes on Wood burning

With a full load of wood, the stove will need to be refuelled approximately once every hour.

Wood can be stacked in the stove, but care must be taken that logs do not touch the baffle. Overloading the stove can cause excess smoke to be emitted.

Wood burns most efficiently with the secondary air valve lever in the open position and the primary control closed. Moving the secondary control will control the burn rate of the stove.

Note - primary and secondary air is needed to light the stove, see section entitled 'Lighting the Stove'

Wood burns best on a bed of ash and it is therefore only necessary to remove surplus ash from the stove occasionally.

If there is insufficient burning material in the fire bed to light a new fuel charge, excessive smoke emission can occur.

Refuelling must be carried out with a sufficient quantity of glowing embers and ash, so that the new fuel charge will ignite quickly. If there are too few embers, add some kindling to prevent excessive smoke.

LIGHTING THE STOVE

We recommend that you have two or three small fires before you operate your stove to its maximum heat output.

This is to allow the paint to cure in steadily and to give a long service life of the paint finish.

During this curing in process you may notice an unpleasant smell. It is non-toxic, but for your

comfort we would suggest that during this period you leave all doors and windows open.

To light the stove open the primary and secondary air controls by pushing both levers fully to the right. Light one or two firelighters placed centrally in the firebox, allowing the flames to become established before placing several pieces of small dry kindling in a criss-cross fashion above the firelighters, taking care not to smother the fire. Close the stove door. Once the kindling is well alight open the door and build the fire by gradually adding slightly larger pieces of wood, closing the door afterwards.

Once you have a good fire established across the firebox bed, further fuel can be added as required and the air controls set to the correct position (see 'Notes on Wood burning').

Should the fire fail to light correctly open the door and use a poker to spread the fuel across the firebox. Close the door and allow the fuel and stove to cool before attempting to relight the fire.

N.B. Leaving the air controls in the closed position, adding too much fuel or using wood that is wet or too large will prevent the fire from establishing correctly and may result in smoke emission from the stove.

Reduced Combustion

In order to shut down the stove, close the primary control, then close the secondary air slider by moving the handle all the way to the left.

If the controls are left in this position, the fire will be starved of air and will die down.

If you want to revive the fire it is recommended that the primary air control is open first, and then open the secondary air slider.

Warning!- The stove will remain **hot** for a considerable time after the fire has been extinguished.

Recommended Fuels

Hunter Stoves recommend that wood logs are burnt in this appliance.

Burn only dry, well-seasoned wood, which should have been cut, split and stacked for at least 12 months, with free air movement around the sides of the stack to enable it to dry out.

Burning wet or unseasoned wood will create excess smoke emissions, tar deposits in the stove and chimney and will not produce a satisfactory heat output.

Only authorised smokeless fuels may be used in smoke control areas.

Warning! - Petroleum coke fuels or household waste must not be burnt on this appliance.

This appliance should not be used as an incinerator.

No liquid fuels should be burnt on this appliance.

Should any difficulties arise over fuel quality or suitability, consult your local approved coal merchant or:

HETAS Ltd – Telephone 01242 673257 – www.hetas.co.uk

Solid Fuel Association – Telephone 0800 600 000 – www.solidfuel.co.uk

GENERAL MAINTENANCE

This appliance requires regular maintenance by a competent person.

Baffle

This should be removed and cleaned at least once a month to prevent any build up of soot or fly ash that could lead to blocked flueways and dangerous fume emission.

If the baffle is removed the chimney/flueway can be swept through the appliance.

Stove Body

The stove is finished with a heat resistant paint and this can be cleaned with a soft brush.

Do not clean whilst the stove is hot.

The finish can be renovated with Hunter Stoves paint.

Glass Panel

Clean the glass panel when cool with Hunter Stoves glass cleaner.

Highly abrasive substances should be avoided as these can scratch the glass and make subsequent cleaning more difficult.

Wet logs on heated glass, a badly aimed poker or heavy slamming of the door could crack the glass panel.

The glass will not fracture from heat.

Firebricks

In normal use, these can last for many years. It is possible however, to crack them if logs are continually jammed against them or if they are frequently struck with a poker.

Check periodically for seriously cracked bricks, which can be replaced with new, available from your dealer.

Door Catch

The door catch may require adjustment to maintain the door seal.

To adjust the catch:

- ▶ Loosen the M6 nut located at the rear of the door catch mechanism.
- ▶ Rotate the barrel catch one complete turn to achieve the correct door operation.
- ▶ Retighten the M6 nut.

Rope

Check the rope around the door. If rope is becoming detached, use Hunter Stoves rope glue to reattach it. If the rope is in a poor condition, a replacement rope kit may be ordered from the Hunter Stoves spares range.

Chimney and Flueways

It is important that the chimney, flueways and any connecting flue pipe are swept regularly. This means at least once a year for smokeless fuels and at least twice a year for wood and other fuels.

The baffle will need to be removed from its supports in order to sweep the chimney (see assembly instructions).

Only wire-centred sweeps' brushes fitted with a guide wheel should be used.

If it is not possible to sweep all parts of the chimney through the appliance, ensure there is adequate access to cleaning doors.

Periods of prolonged non-use

If the stove is to be left unused for a prolonged period of time then it should be given a thorough clean to remove ash and unburned fuel residues. To enable a good flow of air through the appliance to reduce condensation and subsequent damage, leave the air controls fully open

If the appliance has been unused for a long period of time, such as during the spring and summer months, a competent person should check the chimney for potential obstructions before lighting the stove.

Gaskets

All gasket used on this appliance are produced from a heat resistant material called Manniglas.

The glass gasket will have to be replaced when a new piece of glass is fitted as the gaskets become brittle after firing the stove.

Over time you may also find that the gasket changes colour. This is due to a reduction in the pigment used in the manufacture of the product and no cause for concern.

Troubleshooting

Fire will not burn

Check that:

- ▶ The air inlets are not obstructed in any way.
- ▶ Chimneys and flueways are clear.
- ▶ A suitable fuel is being used.
- ▶ There is an adequate air supply into the room.
- ▶ An extractor fan is not fitted in the same room as the stove.
- ▶ Flue draught is above minimum level (see installation instructions).

Fire blazing out of control

Check that:

- ▶ The doors are tightly closed.
- ▶ The air controls are all in the closed position.
- ▶ A suitable fuel is being used.
- ▶ The glass retaining clips are not loose.
- ▶ The door rope seals are in good condition
- ▶ Flue draught is below maximum level (see installation instructions).

Spares Information

Single Door spares

Single Door
(HH04/055)

Door Handle
(HCR06/059)

Door Cover
(HH04/056)

Rope Sealing Kit
(SCPH4SDSK)

Glass Gasket
(HH04/058)

Door Slider
(CH05/009)

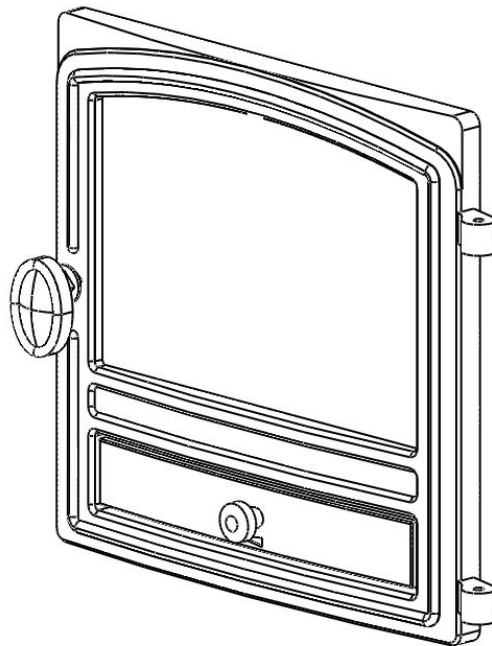

Door Glass
(HH04/057)

Slider Knob
(HHR08/045)

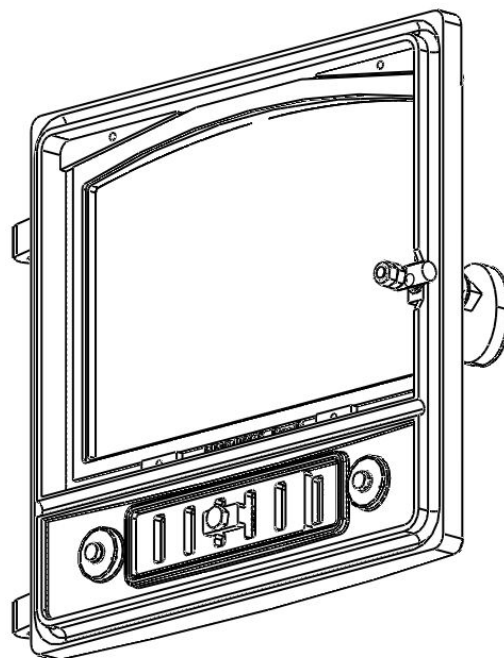

Door Catch Assembly
(DCH4)

Glass Clip
(HHR08/046)

Glass Clip Screw
(FSJM05008SS)

Double Door spares

Right Hand Door
(HH04/069)

Right Hand
Door Cross
(HH04/071A)

Door Handle
(HCR06/059)

Slider Knob
(HHR08/045)

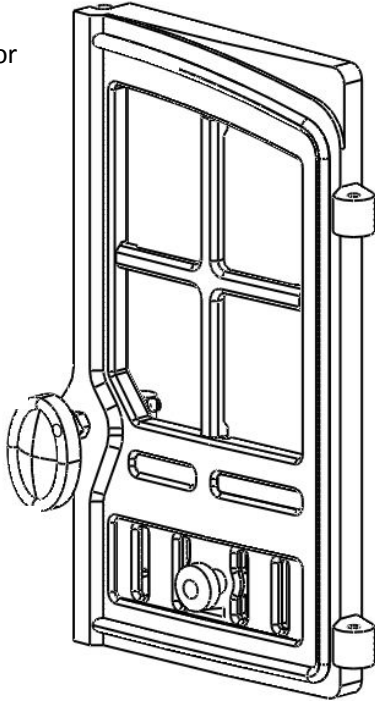

Glass Clip
(HHR08/046)

Glass Clip Screw
(FSJM05008SS)

Rope Sealing Kit
(SCPH4NDSK)

Door Glass
(HH04/073)

Glass Gasket
(HH04/072)

Door Catch Assembly
(DCH4)

Door Slider
(HH04/091)

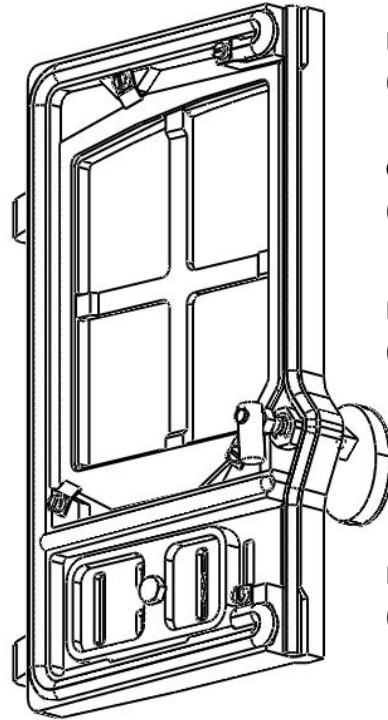

Left Hand Door
(HH04/070)

Left Hand
Door Cross
(HH04/071B)

Slider Knob
(HHR08/045)

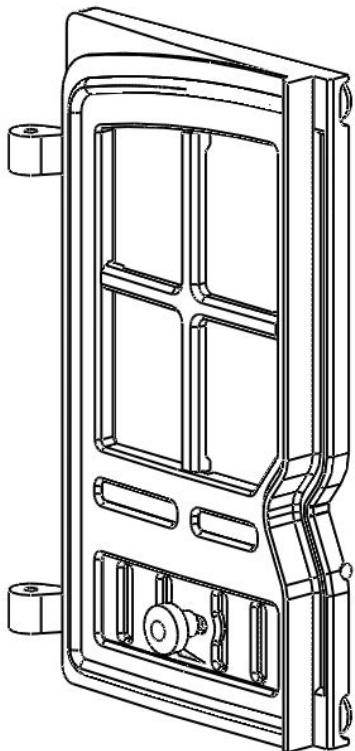

Glass Clip
(HHR08/046)

Glass Clip Screw
(FSJM05008SS)

Rope Sealing Kit
(SCPH4NDSK)

Door Glass
(HH04/073)

Glass Gasket
(HH04/072)

Door Slider
(HH04/091)

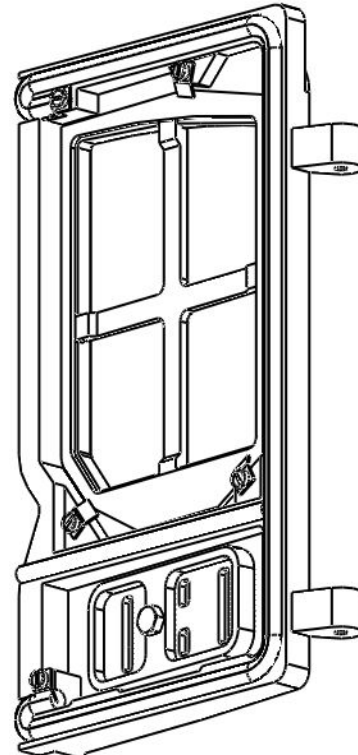

Body Assembly Spares - Wood

