

Your local ESSE Centre can guide you through our range to ensure you find the perfect ESSE for your home.



ESSE



ESSE

MADE IN BRITAIN

ESSE Engineering Limited, Long Ing,
Barnoldswick, Lancashire BB18 6BJ

01282 813235

enquiries@esse.com | www.esse.com

First published 1854. This edition 2018. Every ESSE stove is made in the United Kingdom.

"ESSE" is a trade mark of ESSE Engineering Limited © ESSE Engineering Limited 2018. All rights reserved. No part of this publication may be reproduced in any form or by any means without the prior written permission of ESSE Engineering Limited. We are constantly developing and improving our products. We reserve the right to alter specifications without prior notice.



THE QUINTESSENCE of COMFORT

There's nothing quite like the joy derived from making your own log fire and feeling that first burst of warmth as you sit back for the evening. At ESSE we share that joy when we hand build our beautiful stoves which we have done for over 160 years.

01282 813235

ESSE

esse.com

MASTER
STOVE
MAKER
SINCE 1854

ESSE

ESSE has been hand-building stoves and cast iron cookers for more than a century and a half. Our stoves have been tried, tested and trusted across the world.

From the frozen wastes of the Antarctic, to hotels and hospitals throughout the British Empire - ESSE cookers and stoves have historically been relied upon in some of the most gruelling environments you could ever expect.

Every stove is hand built in Britain with pride, just as they have been for over 160 years.

Not only are these stoves built with attention to detail by skilled craftsmen, they are also some of the most energy efficient on the market, helping save on energy bills and running costs.

A wide range of styles and specifications ensures there is a stove to suit you and your home perfectly. Choose top or rear flue options to make the best use of your fireplace.

There are double-door models and even a stove that cooks to perfection. Every ESSE stove (except the Ironheart) is smoke-exempt making them suitable for burning wood in smoke control areas thanks to an innovative, clean-burning design. ESSE stoves also feature Afterburn™ airwash technology for clear door glass and exceptional burn rate control.

All ESSE stoves offer an excellent energy efficiency rating, most with over 80% for glowing and economical warmth, day and night.

ESSE gas stoves are also available, with or without flues, and even as wall-mounted models.

Have you seen ESSE's stunning range cooker collection? There are more than 20 colours to choose from, and a host of sizes and fuel types. Find out more at esse.com or call 01282 813235.

CONTENTS

4	500 Vista
5	700 Vista
6	100
7	100 / 200 DD
8	200
9	100 KC
10	525
11	125 / 225
12	550
13	150 / 250
14	Ironheart
15	301 / 350
16	Log Store
17	Automatic Ignition
18	Vector
19	Dimensions

OVER 160 YEARS OF ENERGY-EFFICIENT STOVE DESIGN

1854

Edinburgh-born James Smith sought his fortune in America, developing closed stoves for the pioneers of the 'Wild West'. Smith brought this design back to Scotland and began producing ESSE stoves just before the outbreak of the American Civil War. 'Bontesse' was the first British stove to burn anthracite. It's interesting to note that right from the start ESSE was promoting fuel economy and clean-burning designs.

1900

Shackleton and Scott relied on ESSEs during their expeditions across the frozen wastes of the Antarctic.

Circa 1910

The 'Pioneer' stove was a dedicated wood burner with secondary manifold to reburn smoke, offering exceptional performance and cleaner emissions.

1950

By the mid 1900s, ESSE cookers and stoves had gained popularity in restaurants, royal households, hotels and homes across the world.

1970

With the Suez oil crisis, ESSE launched 'The Dragon', styled directly from the original 1854 'Fame' shown below, but with a large capacity, wide body to take logs. The elaborate design received critical acclaim and proved extremely popular.

2000

ESSE's stove collection continues to develop, with energy-efficient models in all fuel types. Wood models become available as 'smoke exempt', suitable for use in smoke control areas.

2004

The iconic Ironheart is unveiled to celebrate ESSE's 150th anniversary. The cookstove is soon chosen for River Cottage by Hugh Fearnley-Whittingstall and his famous farm.

2011

ESSE stoves are once again used on an Arctic expedition. So successful are they in this hostile environment that they are also used in Japan's disaster relief efforts.

2016

ESSE integrates a stylish and practical log store into the design of numerous models, as well as introducing a stay-cool wooden handle option. ESSE's automatic ignition is unveiled; an electric ignition system for multi-fuel stoves.

2018

Introduction of the '50' stoves featuring cleaner lines, longer legs and large viewing windows. The new door design creates a minimalist look that's bang on trend for an urban industrial chic interior.



1854's ESSE 'Fame'

2018 ESSE 150 SE

Since 1854 we have been creating stoves that burn cleanly and efficiently. ESSE stoves have been evolving for over 160 years, and we maintain the same ethos of fuel economy and energy efficiency to this day.



500 VISTA 5kW

500 Vista is the quintessential ESSE, with our signature door styling and technologically advanced performance. Wide, clean glass offers an unrivalled fire view while an efficient fire box with tertiary air ensures great fuel economy. A high quality steel body gives the Vista endurance. The attractive cast iron detail on the top, door and feet complete the stove. The Vista is a simple-to-use 5kW multifuel stove, including twin position riddling grate with both wood and mineral fuel settings. For ease of installation, the Vista features a flue draft test point.

AVAILABLE COLOURS



ENERGY RATED	A+
EFFICIENCY	83.5%
500 VISTA SE	
OUTPUT	5.0kW
FLUE PIPE DIAMETER	5" (125mm)
APPROVED FOR USE ON DECORATIVE HEARTHES	YES
WEIGHT	60KG
TERTIARY AIR	YES
CLEARANCES TO COMBUSTIBLES	400mm sides, 450mm top, 305mm front, 400mm rear
AVAILABLE IN GAS / FLUELESS GAS	YES
AVAILABLE WITH LOG STORE	220mm (H)
TOP AND REAR FLUE OPTIONS	YES



700 VISTA 9kW

The largest model in our popular Vista range, the ESSE 700 Vista is a multi-fuel stove with a powerful 10.5 kW heat output. Its majestic stature makes it ideal for large fireplaces. A twin position riddling grate makes the ESSE 700 Vista ideal for burning both wood and mineral fuels. Primary and secondary air controls provide simple yet complete control over the 700 Vista's impressive output. This stove can be installed with an external air kit so that all primary and combustion air can be supplied via a pipe fixed directly through an outside wall as an alternative to a room air vent.

AVAILABLE COLOURS



ENERGY RATED	A
EFFICIENCY	78.5%
700 VISTA SE	
OUTPUT	9kW
FLUE PIPE DIAMETER	6" (150mm)
APPROVED FOR USE ON DECORATIVE HEARTHES	YES
WEIGHT	102KG
ADDITIONAL ROOM VENT	(3025mm ² or Ø 62mm)
CLEARANCES TO COMBUSTIBLES	400mm sides, 400mm rear, (250mm with additional heat shield), 450mm top, 305mm front
AVAILABLE WITH LOG STORE	300mm (H)
TOP FLUE ONLY	YES



100 5kW

The ESSE 100 is everything a stove should be. It offers the trademark ESSE wide fire view, clear glass, and a slim profile, making it ideal for where hearth depths are limited and for rooms where there is space for a larger stove but a bigger heat output would overwhelm the living space. Levelling feet mean this stove can sit perfectly on an uneven hearth. It is available with top or rear flue installation with an ESSE rear flue box kit. A twin position riddling grate makes the ESSE 100 ideal for burning both wood and mineral fuels. Simple air controls make it easy to operate efficiently.

AVAILABLE COLOURS



ENERGY RATED	A
EFFICIENCY	82%
100 SE	
OUTPUT	5.0kW
FLUE PIPE DIAMETER	5" (125mm)
APPROVED FOR USE ON DECORATIVE HEARTHES	YES
WEIGHT	84KG
ADDITIONAL ROOM VENT	NO
CLEARANCES TO COMBUSTIBLES	600mm sides, 450mm top, 305mm front, 600mm rear
AVAILABLE WITH LOG STORE	300mm (H)
TOP AND REAR FLUE OPTIONS	YES



100/200 DOUBLE DOOR 5kW/7.5kW

AVAILABLE COLOURS



The ESSE 'DD' is the traditional double door version of the popular ESSE 100 and 200. Our modern stoves are designed to be used with the doors closed, and with such clean glass and high performance, there's no reason to burn with doors open. The traditional look of a double door, however, will never go out of style. As with the 100 and 200, the Double Door models have adjustable feet allowing the stove to sit steady on an uneven hearth, the option of either top or rear flue, flue draft test point and simple air controls.

	100DD	200DD
ENERGY RATED	A	A
EFFICIENCY	82%	81.1%
100 DD SE		
200 DD SE		
OUTPUT	5.0kW	7.5kW
FLUE PIPE DIAMETER	5" (125mm)	5" (125mm)
APPROVED FOR USE ON DECORATIVE HEARTHES	YES	YES
WEIGHT	84KG	99KG
ADDITIONAL ROOM VENT	NO	YES
CLEARANCES TO COMBUSTIBLES	100 DD 600, 305, 450, 600 (Side, Front, Top, Rear in mm)	200 DD 400, 305, 450, 400 (200 DD 150mm Rear with additional Heat Shield)
AVAILABLE WITH LOG STORE	300mm (H)	300mm (H)
TOP AND REAR FLUE OPTIONS	YES	YES



200 7.5kW

The 200 offers the same great looks as the 100 but, with its added depth, output is increased to an impressive 8.5kW. The 200 is a multi-fuel stove with twin position grate for burning either wood or mineral fuel. Simple to use, the 200 features a multi-part baffle, allowing adjustment to aid flue draft. This stove can be installed with an external air kit so that all primary and combustion air can be supplied via a pipe fixed directly through an outside wall as an alternative to a room air vent. An optional rear heat shield is available, allowing closer proximity to combustibles.

AVAILABLE COLOURS



ENERGY RATED	A+
EFFICIENCY	81.1%
200 SE	
OUTPUT	7.5kW
FLUE PIPE DIAMETER	5" (125mm)
APPROVED FOR USE ON DECORATIVE HEARTHES	YES
WEIGHT	99KG
ADDITIONAL ROOM VENT	(1925mm ² or Ø 50mm)
CLEARANCES TO COMBUSTIBLES	400mm sides, 400mm rear, (150mm rear with additional heat shield), 450mm top, 305mm front
AVAILABLE IN GAS	YES
AVAILABLE WITH LOG STORE	300mm (H)
TOP AND REAR FLUE OPTIONS	YES



100 KC 5kW

Designed in Iron Grey, the versatile ESSE 100 KC is a stunning multifuel stove with a 5kW heat output. This clean-burning model offers a wide, clear view of the flames. Its tapered legs and air of industrial chic have made it a popular choice for homes throughout the UK. The legs reflect the design of the popular Ironheart cook stove. Like all ESSEs, the 100 KC has been created with the benefit of more than 160 years' stove-building experience.

ENERGY RATED	A
EFFICIENCY	82%
100 KC SE	
OUTPUT	5.0kW
FLUE PIPE DIAMETER	5" (125mm)
APPROVED FOR USE ON DECORATIVE HEARTHES	YES
WEIGHT	84KG
ADDITIONAL ROOM VENT	NO
CLEARANCES TO COMBUSTIBLES	600mm sides, 450mm top, 305mm front, 600mm rear
TOP AND REAR FLUE OPTIONS	YES



525 5kW

A 5kW contemporary stove which is ideally suited to a standard fireplace or builders opening. The spectacular and uncluttered view of the flames is elegantly framed by its stainless steel legs and can be easily controlled by beautifully engineered, minimalist air controls. The firebox door glides open with an effortless action thanks to unique 'invisible' hinges. Its small footprint and moderate output make it easy to plan into a modern living space without overpowering a centrally heated room. The 525 can burn multi-fuel and/or wood.

All black model pictured above, and with brushed stainless steel pillars, right.



AVAILABLE COLOURS

Black	Gold	Bronze
Ash White	Ruby	Iron Grey

ENERGY RATED	A+
EFFICIENCY	83.5%
525 SE	
OUTPUT	5.0kW
FLUE PIPE DIAMETER	5" (125mm)
APPROVED FOR USE ON DECORATIVE HEARTHES	YES
WEIGHT	80KG
ADDITIONAL ROOM VENT	NO
CLEARANCES TO COMBUSTIBLES	400mm sides, 450mm top, 305mm front, 400mm rear
AVAILABLE IN GAS / FLUELESS GAS	YES
TOP AND REAR FLUE OPTIONS	YES



125 5kW 225 7.5kW

The 125 and 225 have all the benefits of the 100 and 200 stoves, with a sophisticated look that makes it well suited to contemporary homes. This stylish stove offers impressive efficiency levels of up to 82% and has a heat output of 5kW / 7.5kW when burning wood. This model is steel-built with a cast door. The 125 and 225 have stainless steel pillars as standard, but can also be supplied as an 'all black' model if specified. ESSE 125 and 225 have a twin position grate, ideal for burning both wood and mineral fuels. Simple top and bottom air controls make it easy to operate efficiently.

Also available with black pillars.



AVAILABLE COLOURS

Black	Gold	Bronze
Ash White	Ruby	Iron Grey

	125	225
ENERGY RATED	A	A
EFFICIENCY	82%	81.1%
100 DD SE		
200 DD SE		
OUTPUT	5.0kW	7.5kW
FLUE PIPE DIAMETER	5" (125mm)	5" (125mm)
APPROVED FOR USE		
ON DECORATIVE HEARTHES	YES	YES
WEIGHT	84KG	99KG
ADDITIONAL ROOM VENT	NO	YES
CLEARANCES TO COMBUSTIBLES	125	600, 305, 450, 600
(Side, Front, Top, Rear in mm)	225	400, 305, 450, 400
(225 150mm Rear with additional Heat Shield)		
TOP AND REAR FLUE OPTIONS	YES	YES





550 5kW

ESSE's multi-fuel stove range has a stylish new addition – the tall, dark and handsome 550SE. Based on the proven and super-efficient ESSE 500, the new arrival features cleaner lines, new longer legs and an oversize clear glass window offering an enticing view of the natural flames dancing within. Ideal as the focal point of a modern open-plan living space, study or the centrepiece of a cosy lounge, the 550 has an energy rating of 'A+', and ESSE's trade-marked clean burn technology enables it to be fired in smoke exempt zones throughout the UK.

AVAILABLE COLOURS



ENERGY RATED	A+
EFFICIENCY	83.5%
550 SE	
OUTPUT	5.0kW
FLUE PIPE DIAMETER	5" (125mm)
APPROVED FOR USE ON DECORATIVE HEARTHES	YES
WEIGHT	51KG
ADDITIONAL ROOM VENT	NO
CLEARANCES TO COMBUSTIBLES	400mm sides, 450mm top, 305mm front, 450mm rear
TOP AND REAR FLUE OPTIONS	YES



150 5kW 250 7.5kW

ESSE's multi-fuel stove range has a stylish new addition. The 150 SE & 250 SE features clean lines, new longer legs and an oversize clear glass window offering an enticing view of the natural flames dancing within. The 150 & 250 have an energy rating of 'A', and ESSE's trade-marked clean burn technology enables these models to be fired in smoke exempt zones throughout the UK. The 150 SE & 250 SE are economical to run and incorporate both primary and secondary air wash controls for precision adjustment of the burn rate and the ability to create some beautiful flame patterns.

AVAILABLE COLOURS

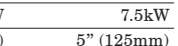

	150	250
ENERGY RATED	A	A
EFFICIENCY	82%	82%
150 SE		
250 SE		
OUTPUT	5.0kW	7.5kW
FLUE PIPE DIAMETER	5" (125mm)	5" (125mm)
APPROVED FOR USE		
ON DECORATIVE HEARTHES	YES	YES
WEIGHT	100KG	99KG
ADDITIONAL ROOM VENT	NO	YES Ø50MM
CLEARANCES TO COMBUSTIBLES	150	600, 305, 450, 600
(Side, Front, Top, Rear in mm)	250	400, 305, 450, 400
(250 150mm Rear with additional Heat Shield)		
TOP AND REAR FLUE OPTIONS	YES	YES



THE IRONHEART EW/EWB

9.7kW(EW) 10.6kW(EWB)



Pictured above,
The Ironheart at
River Cottage



Scan to see the Ironheart on ESSE TV

The Ironheart was created to mark 150 years of ESSE. It combines the quintessential features of a superb multifuel stove and traditional range cooker, celebrating all that ESSE does best. Use it to cook a full roast in the oven - with six pans on the hotplate - or simply to boil the whistling kettle. Toast marshmallows in the firebox or prove dough around the Ironheart's warm edges for baking fresh, crusty loaves. However it's used, the ESSE Ironheart has plenty of cooking and heating potential. It gives out up to 9.7kW to the room. (Available with domestic hot water).

ENERGY RATED	A
EFFICIENCY	81.8%
OUTPUT	9.7kW
FLUE PIPE DIAMETER	6" (150mm)
APPROVED FOR USE ON DECORATIVE HEARTHES	YES
WEIGHT	308KG / 317KG
ADDITIONAL ROOM VENT	YES
CLEARANCES TO COMBUSTIBLES	

EW 300mm sides, 500mm rear, 305mm front
EWB 200mm sides, 400mm rear, 305mm front



301 4kW 350 5kW

Inset stoves offer a very efficient way to heat your room; the firebox sits inside a second outer casing with a cavity between the two. Cool air from the room is drawn in at the base of the stove and heated before rising out of the top into the room. The 301 fits straight into a standard fireplace. The 350 also fits into a standard fireplace, however the brick fire back needs to be removed to accommodate the larger firebox. Unlike 'non-convection stoves' - which radiate heat in straight lines - ESSE inset convector stoves both radiate heat and produce a gentle stream of hot air, evenly warming room.

Also available
with traditional,
diamond-cut door.



	301	350
ENERGY RATED	A+	A
EFFICIENCY	83%	80%
301 SE		
350 SE		
OUTPUT	4kW	5kW
FLUE PIPE DIAMETER	6" (150mm)	6" (150mm)
WEIGHT	60KG	70KG
CLEARANCES TO COMBUSTIBLES	150mm sides, 400mm top, 250mm front	





ESSE FIRST WITH Automatic IGNITION

The Integrated Stove Ignition System

The ESSE brand is steeped in heritage – but time doesn't stand still. ESSE stoves are constantly developing to meet the demands of the home. Now you can have an ESSE with automatic electric ignition.



LOG STORE

Our purpose-designed log store is now available on the ESSE 100, 200, 500 Vista and 700 Vista models. The striking new ESSE log store enables you to neatly keep your fuel close at hand and can be purchased with the stove or retrofitted. It provides a practical and aesthetically pleasing way to keep your chopped wood. It brings rural charm to any home, displaying the natural beauty of cut logs and also serving the practical purpose of raising the stove into a more accessible and easily operable position.

AVAILABLE COLOURS



The table below details which stoves are compatible with which log store.

	220mm	300mm
500 VISTA	x	
100	x	x
200		x
700		x

AUTOMATIC ELECTRIC IGNITION

Hot technology. We have launched a new high-tech fire-lighting system. ESSE wood-burning stoves are the first in the world to use the automatic electric ignition system in the home. The combustion unit ignites the fire inside a wood-burning stove with the touch of a button. It means an end to kindling, matches and burnt fingers.

The ingenious British-invented electronic ignition system is simple to use – load your dry logs in front of the air jet, close the door, press the remote control and the lighting cycle begins.

STEP BY STEP

- 1 - The user initiates the lighting sequence by pressing the start button.
- 2 - The rear vent opens.
- 3 - The fan starts.
- 4 - The heater element starts and hot air is blown onto the fuel. This lights and establishes the fire.
- 5 - After five minutes, the heater element switches off.
- 6 - The fan runs on for another 20 seconds before also switching off.
- 7 - The rear vent automatically closes.
- 8 - Just sit back and enjoy your ESSE, while occasionally reloading with dry logs.

AVAILABLE ON	100, 125, 150, 100 KC, 200, 225, 250 & 700 STOVES
HEATER ELEMENT OUTPUT	2.1kW
LIGHTING CYCLE	5-8 MINUTES
ELECTRICAL SUPPLY	13AMP



VECTOR 2kW

Designed specifically to slot into busy 21st Century lifestyles, this iconic electric heater has been developed for a sophisticated customer looking for style, functionality, performance and flexibility. With a maximum output of 2kW, Vector can provide additional heat for occasional spaces such as spare rooms, home offices, loft and attic spaces, 'man caves', summerhouses and conservatories and it's the perfect appliance to give a welcome boost to the central heating in any room where families want a warm and cosy environment in which to relax.

OUTPUT	UP TO 2kW
ELECTRIC SUPPLY	13AMP
APPROVED FOR USE ON DECORATIVE HEARTHES	YES
WEIGHT	16KG
7 SETTING TEMPERATURE CONTROL	YES

DIMENSIONS

500 VISTA

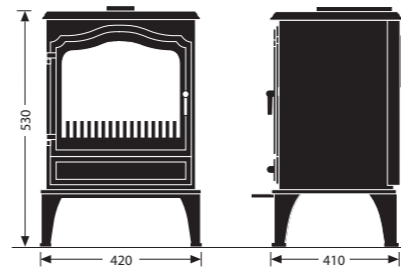

Distance from centre of flue to back of stove 145mm.
Distance from hearth to centre of flue 390mm.

WITH LOG STORE

500 VISTA Stove with 220mm Log Store - total height: 675mm

700 VISTA

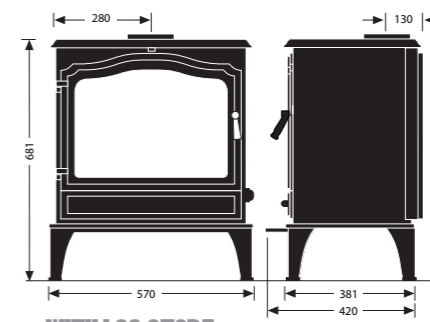

WITH LOG STORE

700 VISTA Stove with 300mm Log Store - total height: 832mm

100/DD / 200/200 DD

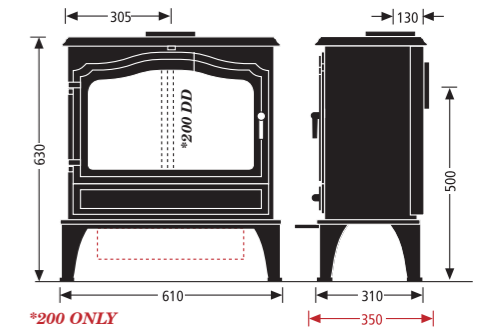

WITH LOG STORE

100 Stove with 220mm Log Store - total height: 715mm
100 Stove with 300mm Log Store - total height: 795mm
200 Stove with 300mm Log Store - total height: 795mm

100KG

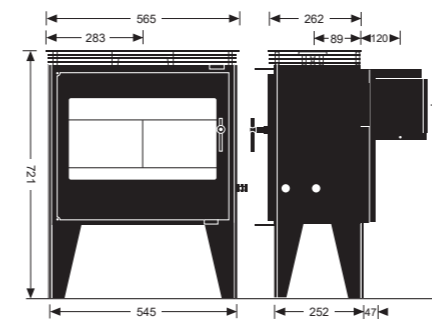

525/525

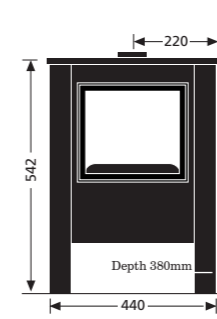

Distance from centre of flue to back of stove 140mm.
Distance from hearth to centre of flue 415mm (585).

125/225

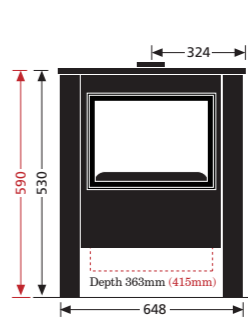

Distance from centre of flue to back of stove 145mm (135mm). Distance from hearth to centre of flue 405mm (453mm). *225 ONLY

550/550

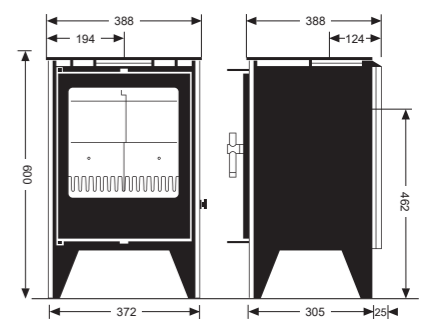

150/250

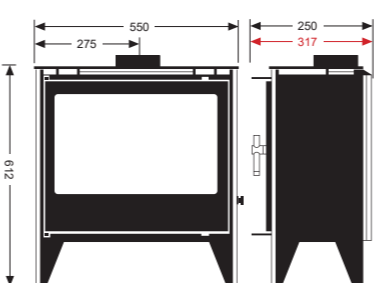

*250 ONLY

301/350

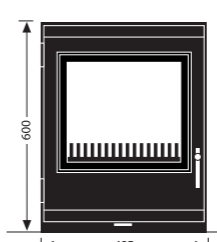

A round flue adaptor is available to allow connection to a flue pipe or flexible chimney liner. This can be connected to the liner and then fitted from inside the stove.

301

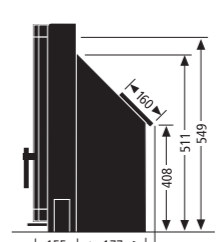

350

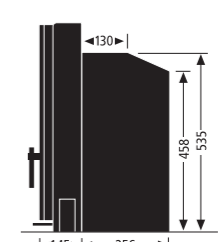

- A) Between 396 & 420mm.
- B) Between 540 & 560mm.
- C) Extending 50mm around opening.
- D) Hearth at least 400mm deep without obstructions that could prevent the door from opening.

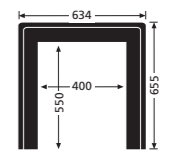

Optional inset steel fitting frame

REAR FLUEBOX

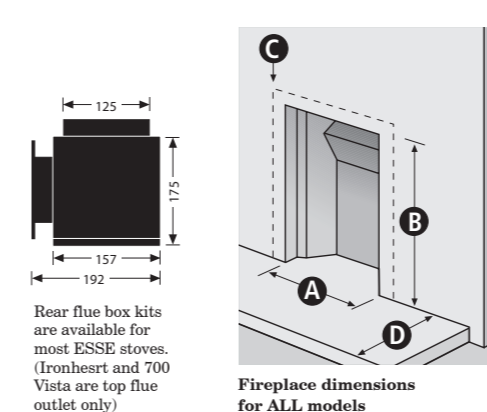

Rear flue box kits are available for most ESSE stoves. (Ironheart and 700 Vista are top flue outlet only)

Fireplace dimensions for ALL models

IRONHEART

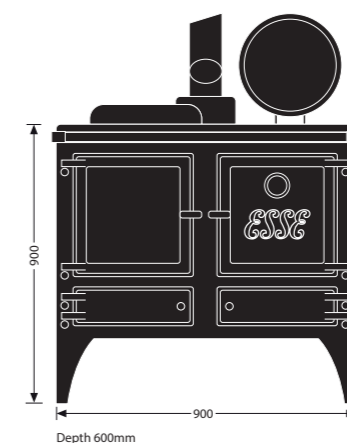

Depth 600mm

VECTOR

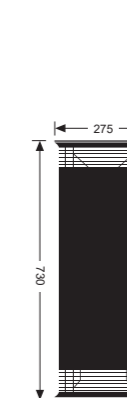

ESSE Product Guarantee
Excluding consumables.
Subject to terms and conditions.
Visit esse.com for further information.

MADE IN BRITAIN