

# **Apex**

Model Options  
Liberty 6 & 10

## **Information & Installation Guide**

**This is not a DIY product and must be installed by a Gas Safe registered installer**

**The information contained herein is not meant to replace the full instructions supplied with the fire on delivery merely supplementary information to help in determining whether either appliance is suitable before purchase**

Edition J 09/15  
Country(s) of destination - GB/IE

## INSTALLATION INFORMATION

This appliance is an Inset Live Fuel Effect appliance that provides radiant or combined radiant and convected heat; it cannot and **should not** be used as the main heating source within a property.

The appliance is designed to fit most types of fireplaces with a natural draught flue as listed in the Installation Requirements.

The appliance must be installed by a competent person in accordance with the Gas Safety (Installation and Use) Regulations 1998.

A Gas Safety Registered installer must be used for this purpose.

Read all these instructions before any installation takes place and in conjunction with the appliance on site.

This appliance must be installed in accordance with the rules in force and only used in a sufficiently ventilated space.

This appliance is factory set and tested for operation on the gas type, and at the pressure stated on the appliance data plate.

After a new gas appliance (excluding flue less cookers) has been fitted, the Building Regulations in England and Wales require that the installation must be notified to your Local Authority. Your Gas Safe registered engineer needs to do this, failure to register the appliance may affect your warranty.

## OPENING THE APPLIANCE

Stand the carton the right way up, open the box from the top.

Read all the instructions before continuing to unpack or install this appliance.

Remove the bags containing ceramic components such as coals or gravel etc. Remove the cardboard packing pieces, and any other bags or boxes containing fittings or other parts.

When all loose parts have been removed, the appliance may be lifted from the outer carton.

Check that the components supplied correlate with the component checklist below.

If for some reason any of the listed components are missing or damaged do **NOT** commence with this installation, in doing so will invalidate your warranty.

Please dispose of all the packaging materials at your local recycling centre.

## CONTENTS CHECK LIST

Qty	Description
1	Firebox and Burner Tray.
1	Chippings/Pebbles.
1	Lengths of adhesive sealing strip.
1	Set of manufacturer's instructions and warranty card.
4	Fixing Screws.
4	Raw Plugs.
1	Remote control handset and battery holder pack.
	<b>Flue adaptor sold separately</b>

## INSTRUCTIONS CONTENT

<b>Section</b>	<b>Contents</b>	<b>Page No</b>
1	Important Notes	5
2	Installation requirements	6
3	Appliance Information	7
4	Ventilation	8
5	Site Requirements	8/9
5.1	Pre-Fabricated Flue box	11
6	Debris Space	11
7	Installation of appliance	11
7.1	Preparing the Opening	12/13/14
7.2	Fitting the Burner Tray	15
8	Fuel Bed	16
9	Commissioning the Appliance	16
10	Operating the Appliance Remote Control	16
11	Setting Pressure	17
12	Spillage Monitoring System	17
13	Testing for Spillage	18
14	Briefing the Customer	19
15	Servicing	20
16	Cleaning the Ceramics	21
17	Troubleshooting Guide	21/22
18/18a	User Instructions	22/35
19	List of Spares	35

## Section 1: IMPORTANT NOTES

These fires are Inset Live Fuel Effect Gas Fires providing radiant warmth. It is designed to operate on Natural Gas only.

It is the LAW that all gas appliances and fittings are installed by a competent person such as a Gas Safe Registered fitter and in accordance with the Gas Safety (Installation and Use) Regulations 1998, the relevant British Standards for Installation, Codes of Practice and in accordance with the manufacturers' Instructions.

The installation shall also be carried out in accordance with the following regulations:

The Building Regulations issued by the Department of the Environment, the Building Standards (Scotland) (Consolidation) Regulations issued by the Scottish Development Department.

BS 1251

BS 4543 part2

BS 5440 parts 1&2

BS 5871 part 3

BS 6461 parts 1&2

BS 6891

BS 8303

Failure to comply with these regulations could lead to prosecution and deem the warranty Invalid.

This appliance must be installed in accordance with the rules in force and used only in a sufficiently ventilated space.

Consult all instructions before installation and use of this appliance.

The appliance must be registered once commissioned with the regulatory governing body.

This appliance is free from any asbestos material. Refractories and coal bed are constructed from ceramic fibre.

**Note - For Republic of Ireland, reference should be made to the relevant standards governing installation, particularly in regard to flue sizing and ventilation. See IS813, ICP3, IS327 and any other rules in force.**

## **Section 2: INSTALLATION REQUIREMENTS**

This appliance **MUST NOT** be installed into a bathroom or shower room, or where steam may be present.

An extractor fan must not be fitted in the same room or space as the appliance as this can affect the safety of the appliance.

The fire has been designed to fit into a fireplace or builders opening conforming to BS 1251 (and meeting certain dimensional requirements).

A natural draught flue system is required, and if previously used for solid fuel or oil burning, the flue and chimney must be swept prior to appliance installation.

The flue must be checked before installation by using a smoke pellet or similar to ensure proper draw and that leakage is not evident at any joints. Repair and re-test as necessary before the appliance is installed.

Any flue box used must be installed onto a suitable non-combustible insulating surface at least 12mm thick, covering the entire base area of the box.

The flue must have an effective height of at least three metres, as measured from the top of the appliance to the top of the flue.

Any flue damper plates or restrictors must be removed and no other restriction fitted to the flue. Where removal is not practical, the restriction must be fixed in the fully open position.

The flue must be connected to only one fireplace, and the flue must not vent more than one appliance.

There must be no opening in the flue apart from the one that the appliance is installed into, and the one venting the gases into the air. A suitable terminal may be fitted, such as class GC1, as regulations allow.

This appliance is suitable for use with a surrounding area or back panel of 150C minimum rating.

## Section 3: APPLIANCE INFORMATION

<b>Liberty</b>	6 Model	10 Model
Gas Group	G20 Natural Gas CAT I2H	G20 Natural Gas CAT I2H
Inlet Pressure	20 mbar	20 mbar
Max Input (gross)	6.5	12.5
Min Input (gross)	4.5	7
Setting Pressure	20 mbar	20 mbar
Gas Inlet connection	8mm Compression	8mm Compression
Overall Height	588mm	654mm
Overall Width	722mm	1121mm
Overall Depth	310mm	330mm
Recess Height	552mm	613mm
Recess Width	605mm	1015mm
Recess Depth	305mm	325mm
Air Vent	N/A	Yes
Pilot Assembly & Thermocouple	THERMACO NG OXI-PG-82-460	THERMACO NG OXI-PG-82-460
Valve	Tesc 01-RF868-15	Tesc 01-RF868-15
Injector	1.78	3.5

## SECTION 4: VENTILATION

The Liberty 6 model does not normally require purpose provided ventilation.

The Liberty 10 model **does** require purpose made ventilation to an outside area in accordance with current regulations.

However, if a second appliance operating within the same room or space must be taken into consideration when assessing ventilation.

When commissioning the appliance spillage is detected, then amongst other problems there may be insufficient natural ventilation for correct operation of the flue.

If spillage is detected with windows closed, but the appliance does not spill with the windows open, this demonstrates a lack of natural ventilation.

If spillage is still detected with the windows open, the flue is at fault.

Installation of an air brick is the best solution to lack of ventilation.

Any ventilation fitted must comply with BS 5871 part 2 and BS 5440 part 2.

Air Vents fitted under or within the immediate vicinity of the appliance must not be used as adverse effects to the operation of the Flame Safety Device (FSD) may occur.

Spillage detected during commissioning is almost always a result of poor flue performance that cannot be corrected by any amount of ventilation.

***For Republic of Ireland ventilation may be required, see IS 813, ICP3, IS 327, and any other rules in force.***

## SECTION 5: SITE REQUIREMENTS

The fireplace opening should be inspected and repairs made where necessary.

This appliance requires a natural draught flue system which may be one of the following;

225mm x 225mm (9in x 9in) brick or stone (ALL MODELS WILL FIT)

175mm (7") Minimum diameter lined flue (ALL MODELS WILL FIT)

125mm (5") minimum diameter lined brick or stone. (6 MODEL ONLY)

125mm (5") minimum diameter twin wall flue conforming to BS 715, (6 MODEL ONLY)

175mm (7") minimum diameter twin wall flue conforming to BS 715, (ALL MODELS WILL FIT)

Any existing draught device situated under the fireplace must be sealed off.

The opening area must be non-combustible.

It is recommended that a tactile barrier should be place on the floor in front of the appliance to stop the elderly, infirm or Children from direct contact with the hot surfaces of the appliance.

The area immediately above the outlet must form a smooth path into the flue.



The appliance can be used in a no hearth application if the installation complies with BS 5871-3:2005 and appliance is installed so that the height from the base of the fireplace opening to the floor is no less than 300mm.

As with all heating appliances, any decorations, soft furnishings, and wall coverings (i.e. flock, blown vinyl and embossed paper) positioned too close to the appliance may discolour or scorch.

Possible cracking of the plaster may occur with this type of appliance, combined with the variations of plaster conditions and thicknesses from property to property, we recommend that a heat proof plaster be used.

An area of 600mm above plus 300mm on either side and below should be finished with a heat proof plaster, it may be required to use a heat proof screed under the finish, please see contact details below of possible supplies of these goods for your reference.

The Greener Company  
 Huddersfield Road, Elland, WEST YORKSHIRE HX5 0EE  
[www.thegreenercompany.com](http://www.thegreenercompany.com)

Vitcas  
 8 Bonville Road, Brislington, Bristol BS4 5NZ  
<http://www.vitcas.com>

<b>Model 6</b>		<b>MM</b>	<b>Model 10</b>		<b>MM</b>
<b>A</b>	Width	625mm	<b>A</b>	Width	1025mm
<b>B</b>	Height	583mm	<b>B</b>	Height	622mm
<b>C</b>	Depth	310mm	<b>C</b>	Depth	330mm
<b>D</b>	From Floor	300-450mm	<b>D</b>	From Floor	300-450mm

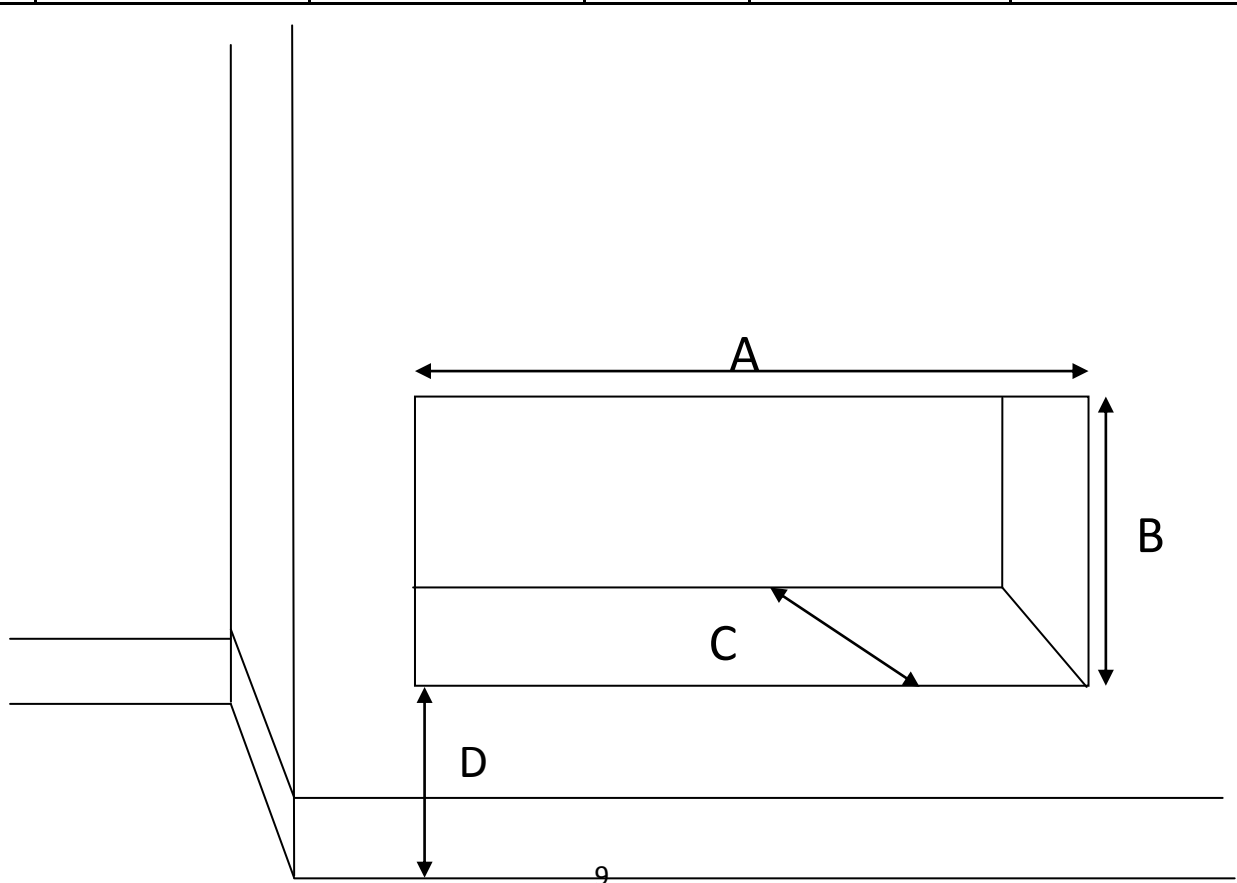

**Note: always check to ensure there is enough room to fit the Spigot plate or flue liner adaptor if required.**

**Note: by not installing the spigot plate may affect your warranty see section 7.1 preparing the opening.**

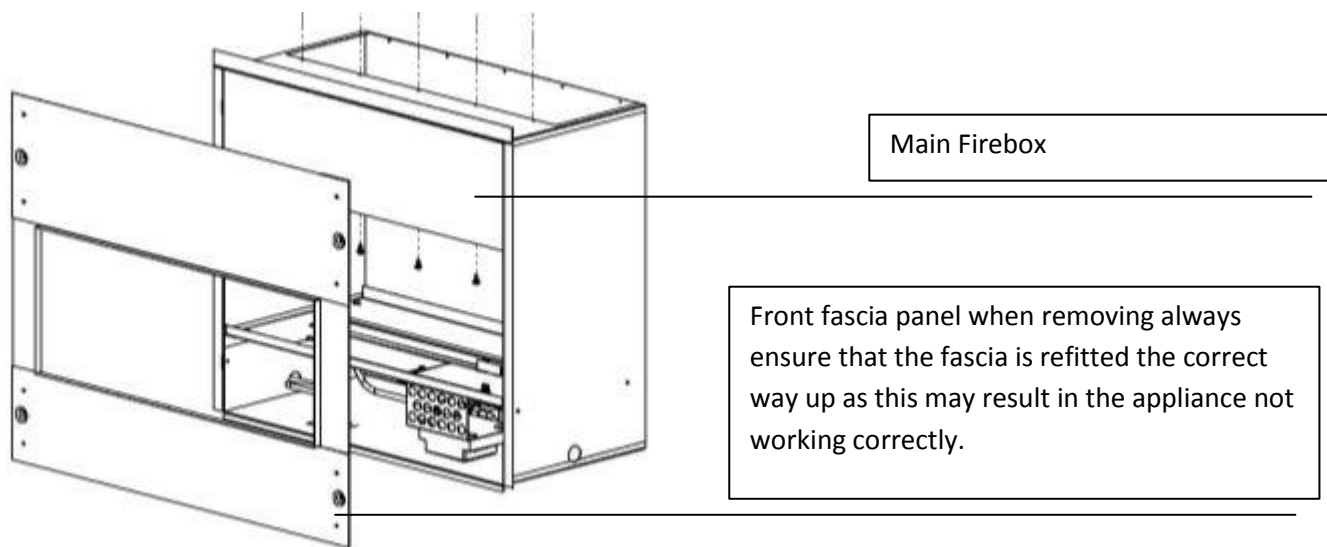

**You will need to remove the plaster from the wall around the fire enough to be able to fix a sheet of master board or non-combustible board over the fire box when in place to be able to be plastered to a finish ready to be decorated.**

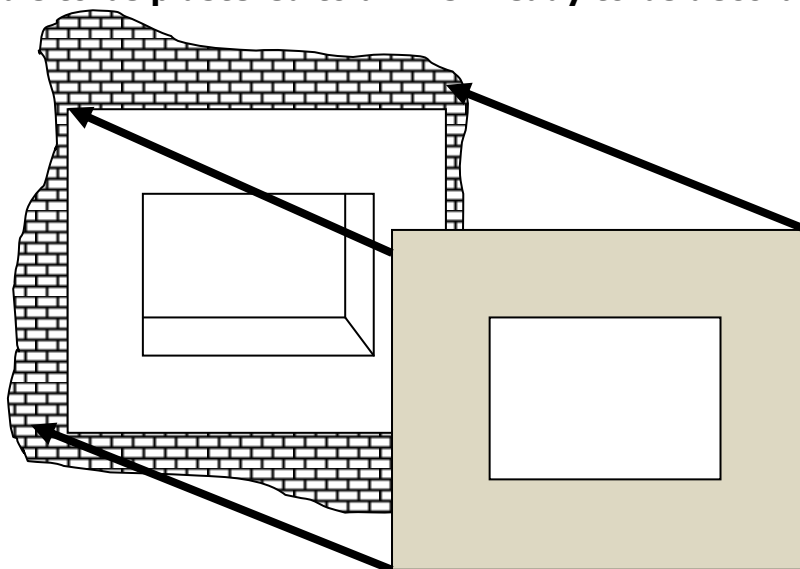

## **SECTION 5.1: PREFABRICATED FLUES**

These appliances can be fitted to a prefabricated flue system; the 6 and 10 appliance can be fitted directly via a flue adaptor (**sold separately**)

All will require a false chimney breast in which to be housed and will need to be constructed of a non-combustible material or any combustible material within 300mm must be clad with a non-combustible board.

The correct clearances to combustible materials (i.e. false chimney breast etc) must be adhered to.

The manufacturer of the prefabricated box's instructions for fitting the prefabricated box must be complied with at all times.

Please ensure the firebox does not obscure the flue box outlet.

It is important that the sealing requirements of the appliance are met at all times and that the flue box is sealed to any back or infill panel.

## **SECTION 6: DEBRIS SPACE**

In accordance with BS 5871 part 2, minimum debris collection volumes are required behind the installed appliance.

CLAY/CEMENT LINES OR BLOCK FLUE WHICH IS NEW, UNUSED, OR PREVIOUSLY ONLY USED WITH A GAS FIRE.

**Appliance recessed depth + 20mm**

UNLINED FLUE OR CHIMNEY WHICH HAS BEEN PREVIOUSLY USED FOR A SOLID FUEL OR OIL BURNING APPLIANCE

**Appliance recessed depth + 60mm**

## **SECTION 7: INSTALLATION OF APPLIANCE**

Always ensure that the gas supply is isolated before commencing installation of the appliance.

The fireplace opening and environment must be in compliance with specifications laid down in the appropriate sections of these instructions.

Remove the appliance from its carton as described previously and stand on a dust sheet.

Place the fuel bed, ceramics and fixings safely to one side.

### **Removing the burner Liberty 6 and 10 Models.**

Remove the burner from the assembly by removing the two screws holding the inspection cover over the isolation valve, and undo the connecting nut to the isolation tap.

Remove the four screws two on each side of the burner tray and undoing the connecting nut to the isolation tap.

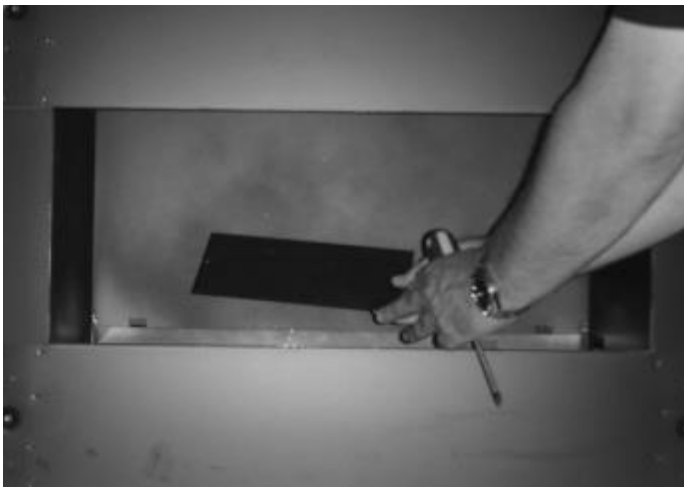

The tray is now free and may be lifted away from the box.

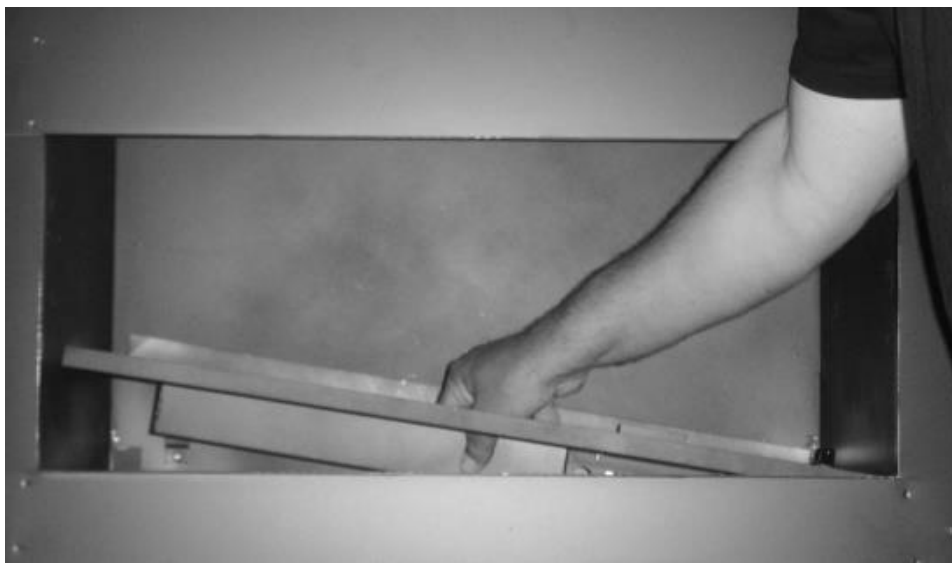

## SECTION 7.1: PREPARING THE OPENING

Before installing the fire, check the flue for correct operation using a smoke pellet, all of the smoke should be drawn up the flue and exit correctly from the terminal.

If problems are found **DO NOT** fit the fire until corrective measures have been completed.

Before running the gas supply into the opening, offer up the fire box to the fireplace to check the fit is good.

Ensure that it slides in correctly, the sealing face sits flat and square to the wall and that the base is level

At this stage it is essential to ensure that the Spigot outlet of the fire is not obstructed in any way.

The Spigot Plate is an integral component for the correct function of the appliance and will invalidate the warranty if this item is not fitted.

Remove the fire box and apply the self-adhesive sealing strips around the edge of the rear of the firebox frame, approximately 5mm in from the edge.

Mark and drill the fire frame in the relevant points on the wall place rawplugs in place.

Push the appliance back into the opening, centralise and securing in to place with the screws provided.

**Note: Fibre Rawplugs might be preferred rather than plastic Rawplugs as the heat from the fire might affect their performance.**

Whilst the opening is ready for installation of the fire, the gas supply can be routed as required and connected to the isolation tap via the 8mm compression fitting.



You can now decide where to route your gas pipe, knock out holes are provided in the rear and side of the fire box for use where concealed pipe work is required.

Knock out the holes with a screwdriver and a sharp tap from a hammer and fit the rubber grommet supplied.

**Note: DO NOT install or use the appliance without this seal in place. Failure to fit this seal correctly will cause the flue suction to act upon the area under the burner tray resulting in poor performance, and overheating of this area.**

**Note: In no circumstance should you use soft soldered connections to or underneath the burner tray.**

The isolator tap or restrictor elbow must be fitted to the incoming supply to facilitate servicing.

The gas pipe must be suitably protected where it passes through fireplace openings. Any sleeving should be sealed to the pipe at its ends.

The open end of the gas supply pipe should be temporarily sealed to prevent ingress of dust and dirt during installation.

## FLUE SPIGOT

When fitting the appliance with a flue liner an adaptor will be required for the Liberty 6 and 10 models. With the fire box in place and the burner tray removed if a flue liner is required the flue adaptor (**available separately**) should be fitted now. Attach the liner to the outlet spigot of the flue adaptor fix into place by lifting into position through the fire box opening securing in place with self-tapping screws supplied.



When fitting the **Liberty 6 appliance only** without the use of a chimney liner then the spigot plate must be fitted, no plate is required with the Liberty 10 model.

Place the two pieces of protective card placed around the spigot plate on either side of the fire box to protect the internal paint work.



Then pass the plate through the fire opening taking care not to damage the firebox and pass through the locating slots either side of the fire outlet.



Then locate the back edge in the internal canopy as shown below

Locate plate back edge  
in back of canopy

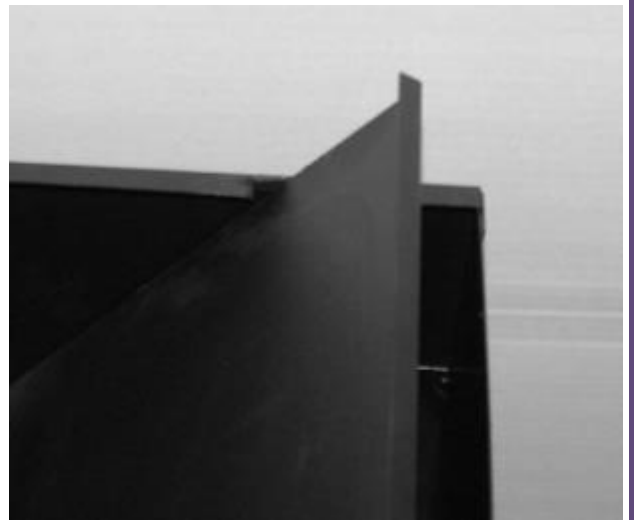
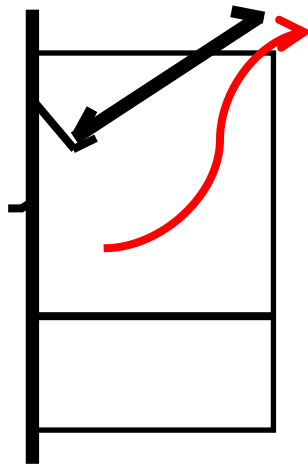

**With the 10 model the spigot diverter is incorporated within the appliance and can be fitted directly into the flue without any additional work.**

## **SECTION 7.2: FITTING THE BURNER TRAY**

Temporarily fit the burner tray and ensure a suitable gas route can be achieved.

Now simple reverse of the previous instructions on how to remove the burner tray. On the remote version please take care not to pull or overstretch the electrical connections as this may cause the fire to fail on commissioning.

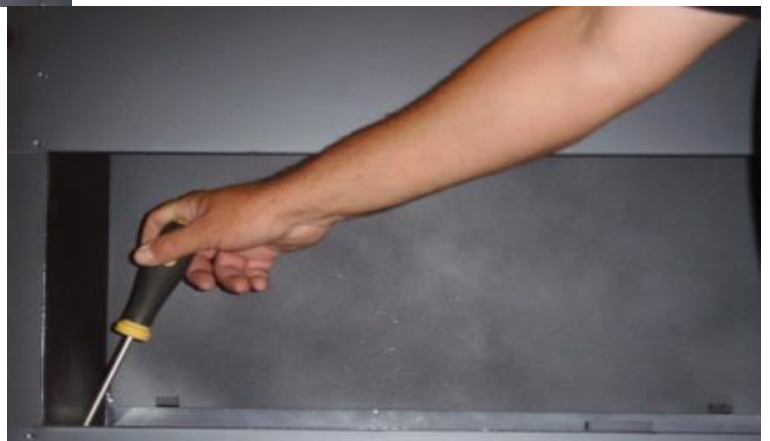

## **SECTION 8: FUEL BED LAYOUT**

Place the chippings Grey or Black all over the burner area, place these by the handful do not pour as the dust could block the pilot assembly.



Leave the area around the pilot assembly clear to allow for good cross-lighting.

Place any additional fuel bed options as per their instruction with these options.

## **SECTION 9: COMMISSIONING THE APPLIANCE**

Turn on and test the gas supply up to the fire for any leaks, in accordance with current Approved Codes of Practice (ACOPs)

## **SECTION 10: OPERATING THE APPLIANCE (Remote control)**

**See Section 18 Users Instructions**



## SECTION 11: SETTING PRESSURE

Remove the pressure test point sealing screw from the isolation elbow and attach a suitable pressure gauge.

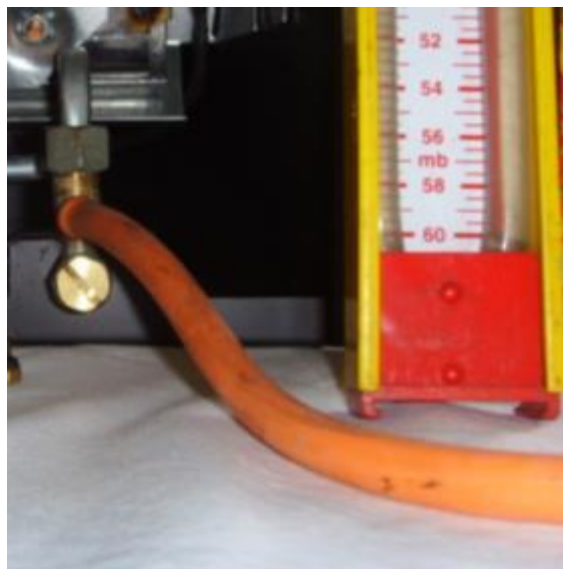

Check that the standing inlet gas pressure is at 20 mbar

Light the pilot and check the correct operation of the burner at all the flame settings.

Refer to the Operating instructions section 10.1

Check that the inlet gas pressure is at 20 mbar when the fire is at its highest setting.

Once the fire has been lit for 5 minutes, turn the gas OFF at the isolating elbow.

After a further 3 minutes turn the gas supply ON again, if the gas has stopped flowing, the Flame Supervision Device (FSD) is operating correctly.

Always check that the gas has stopped flowing even if you hear the FSD valve close within the 3-minute period.

Turn OFF the appliance and the gas supply and refit the pressure test point sealing screw.

## SECTION 12: FLUE SPILLAGE MONITORING SYSTEM

Apex fires are fitted with a flue spillage safety device (ODS).

If the fire shuts down during use for no apparent reason then several things may be suspected, if a door or window has been opened creating a draught, then pilot disturbance is the problem, and removal of the draught should resolve this.

The gas pressure reaching the fire must also be checked (again, recalls your installer to check and rectify any problem).

The thermocouple connection into the back of the gas control valve may also have worked loose during installation, simply get the installer to tighten.

If pilot disturbance is not the cause, then the ODS safety system may be in operation.

Switch the appliance OFF, check the flue and carry out any remedial work required.

Relight the fire and carry out a spillage test, DO NOT allow the appliance to be used if it continues to fail a spillage test.

The aeration hole of the pilot must be carefully cleaned out on each annual service to ensure continued function of the ODS.

The spillage monitoring system shall not be adjusted, modified, or put out of operation by the installer.

Any spare parts fitted MUST be of a type supplied for the purpose by the appliance manufacturer.

If the fire is not spilling, then further guidance should be sought, using the Troubleshooting section as a guide

## **SECTION 13: TESTING FOR SPILLAGE**

Close all doors and windows to the room containing the appliance.

Let the fire run on HIGH for five minutes.

Take a smoke match, light it, and using a smoke match tube, hold it at the top edge of the fire opening, 25mm down and 25mm in.

Run the smoke match across the opening, all the smoke should be drawn away up the flue.

Any smoke returning into the room indicates that spillage is occurring.

If the initial spillage test fails, run the fire for a further 10 minutes and repeat the test.

When the test has been completed satisfactorily, repeat with any extractor fans in the premises running on the highest setting, and any communicating doors open.

Finally, repeat with all doors open.

**DO NOT** allow the fire to be used until the test is satisfactorily passed.

## SECTION 14: BRIEFING THE CUSTOMER

All instructions must be handed to the user for safekeeping.

Show the customer how to light and operate the fire.

After commissioning the appliance, the customer should be instructed on the safe use of the appliance and the informed for the need of regular servicing.

Frequency of service depends on usage, but **MUST** be carried out at least once annually.

Cleaning of the fire may be achieved when the fire is cold using a damp cloth and mild detergent on most surfaces, with the exception of the ceramic fuel bed.

A soft brush i.e. paint brush may be used to clean the ceramic fuel bed taken care not to use excessive pressure.

Scratched and other superficial damage to the matt black paintwork of the appliance can be covered with matching heatproof spray.

Use only the manufacturers' recommended spray paint.

Paint only when the fire is OFF and cold. Always mask off the surrounding area to prevent contamination with overspray.

Ventilate the room during the use of the spray. DO NOT attempt to spray paint the coals or ceramics, or wash them in water.

Advise that the fire will emit a "newness" smell for a time after initial commissioning and that extra ventilation may be needed during this time.

Advise that the fire is fitted with a spillage safety device (O.D.S.). If the fire shuts down, this system may be in operation.

If spillage is suspected, SWITCH APPLIANCE OFF and call in the installer to investigate any problems

## **SECTION 15: SERVICING**

Isolate the fire from the gas supply.

Ensure that the fire is fully cold before attempting service.

A suggested procedure for servicing is detailed below:

1. Lay out the dust sheet and tools required.
2. Carefully remove the ceramic components
3. Remove the two screws that retain the access plate and remove cover to allow access to the isolation tap, turn off the gas at this valve and disconnect the burner tray.
4. Remove the four screws that retain the burner tray in place and gentle lift out careful to disconnect all electrical components.
5. Check the firebox opening for debris and dust and remove.
6. Check the flue with smoke pellet for correct operation.
7. Strip off the burner pipes and clean thoroughly.
8. Clean out the injector, pilot assembly and burner tube. DO NOT remove the pilot injector.
9. Re-assemble and re-fit the burner tray.
10. Turn on the gas supply, and leak test.
11. Refit the decorative fuel bed and ceramics.
12. Check any purpose provided ventilation is un-obstructed.
13. Light the fire and test for spillage.
14. Check setting pressure and safe operation of the appliance.

## **SECTION 16: CLEANING THE CERAMICS**

Remove the ceramic components.

Gently clean in the open air using a dry paint brush.

Be careful not to create dust from the coals.

Where necessary replace damaged components with genuine spares.

Seal scrap ceramic components in plastic bags and dispose at proper refuse sites as directed.

Re-fit the fuel bed by referring to the relevant sections of these instructions.

## **SECTION 17: TROUBLESHOOTING GUIDE**

### **Fire sparks but pilot Flame does not light?**

No gas to fire, check isolating valves are open.  
Pipe work blockage, clean out.  
Air not fully purged, re-purge supply, reset gap correctly.  
Blocked pilot, clean out internally.

### **A pilot lights, but then goes out before main burner lights?**

Severe restriction in gas supply, clear obstruction.  
Thermocouple not operating correctly check connections.  
Run through lighting system on the remote control several times allowing the valve to rest each time.

### **Fire does not spark at pilot?**

HT lead detached, refit.  
Spark gap too large or small reset correctly.  
Spark shorting to metalwork under tray re-aligns HT lead

### **Fire runs for a time and then cuts off?**

Excessive room draught or flue pull, rectify.  
Loose or faulty thermocouple, rectify.  
O.D.S system in operation.  
Firebox grommet seal not fitted, rectify.  
Lint in pilot aeration hole, clean thoroughly internally

### **Pilot flame shrinks when fire is on high?**

Poor gas flow to fire, check pressure with fire on high.  
If pressure is low, remove any restriction in pipe work or valve.  
Check all isolators are adequately sized and fully open.  
Check meter pressure is adequate.  
Air leak under base of firebox, rectify.  
Lint in pilot aeration hole, clean thoroughly internally.  
Firebox grommet seal missing, rectify

### **Fire smells when first lit or in use?**

Newness smell from brand new appliance.  
Spillage occurring, the installer needs to carry out spillage test and rectify any problems.  
Low temperature sealants or combustible materials used in incorrect positions.  
Air leak under base of firebox, rectify.

## **SECTION 18: USER INSTRUCTIONS**

### **IMPORTANT NOTES**

The installation of this fire MUST only be carried out by a competent person (such as a Gas Safe registered fitter) in accordance with the Gas Safety (Installation and Use) Regulations 1998, the relevant British Standards, Codes of Practice, the Building Regulations and the manufacturers' instructions.

Failure to comply with the above recommendations could lead to prosecution and invalidate the appliance Warranty.

Please ensure you are handed all of the manufacturer's documents on completion of the installation. This will include these instructions.

Always keep a note of the installer's name and address, the original purchase receipt and the date of installation for future reference.

The fire and flue should be serviced regularly to ensure continued safe operation, see the servicing section for further details.

Frequency of service will depend on use, but MUST be carried out at least once within a 12 month period.

Parts of this appliance become naturally hot during use, it is recommended that a suitable fire guard conforming to BS 6778 is used, especially where young children, the elderly, or infirm are concerned.

Combustible items, such as flooring and furniture, and soft wall coverings (such as blown vinyl or embossed paper) may discolour if fitted too close to the fire.

See relevant section for further details on clearances to combustibles.

No combustible material or flooring should protrude onto the hearth.

DO NOT burn any foreign material on this fire, the coals must be of the correct type and lay out in accordance with the relevant section of these instructions.

Failure to do so could create a hazard or lead to sooting.

Before the appliance is installed, the chimney should be swept.

All flues should be checked by the installer to ensure there are no defects or obstructions that may prevent the flow of combustion products.

The fire is only suitable for use with the gas type for which it is supplied.

This fire is supplied with a particular style of fire front/fret, use of the fire front/fret will ensure an adequate airflow under the fire bed for the correct functioning of this appliance.

Compliance with safety standards cannot be guaranteed if another style of front is used.

A combustible shelf may be fixed to the wall above the fire, providing that it complies with the dimensions given in section 3 site requirements.

No purpose provided ventilation is normally required for this appliance.

The requirements of other appliances operating in the same space or room, and the results of a spillage test must be taken into consideration when assessing ventilation requirements, this will have been carried out by your Gas Safe registered installer.

***For Republic of Ireland, ventilation may be required, see IS 813, ICP3, IS 327, and any other rules in force.***

**SECTION 18a: OPERATING THE APPLIANCE (Remote**  
**IMPORTANT USER INFORMATION – AFTER INSTALLATION BY THE ENGINEER,**  
**READ THIS BEFORE ATTEMPTING TO OPERATE THE FIRE**

Insert the batteries in the TESC Control and handset as show inside the battery cover and slide isolation switch to the I position on the gas control.



Hold the handset and the green unlock light will illuminate allowing the buttons to work.





Press and hold in the power symbol button and release immediately when the word pilot appears at the bottom left of the display (after about 1-2 seconds). The fire will light.



To Adjust the flame hold the handset to enable the buttons to work and press and the - button to reduce the flame. Press the + button to increase the flame.



To stop the fire, hold handset to unlock the buttons and then press the power button.

## Quick start user instructions

### Fire Control

This control is situated on your fire. The drawing shows the main features of the control.

The control required **3 x AA size alkaline batteries** to be inserted under the battery compartment cover. The orientation of these is shown moulded into the battery compartment.

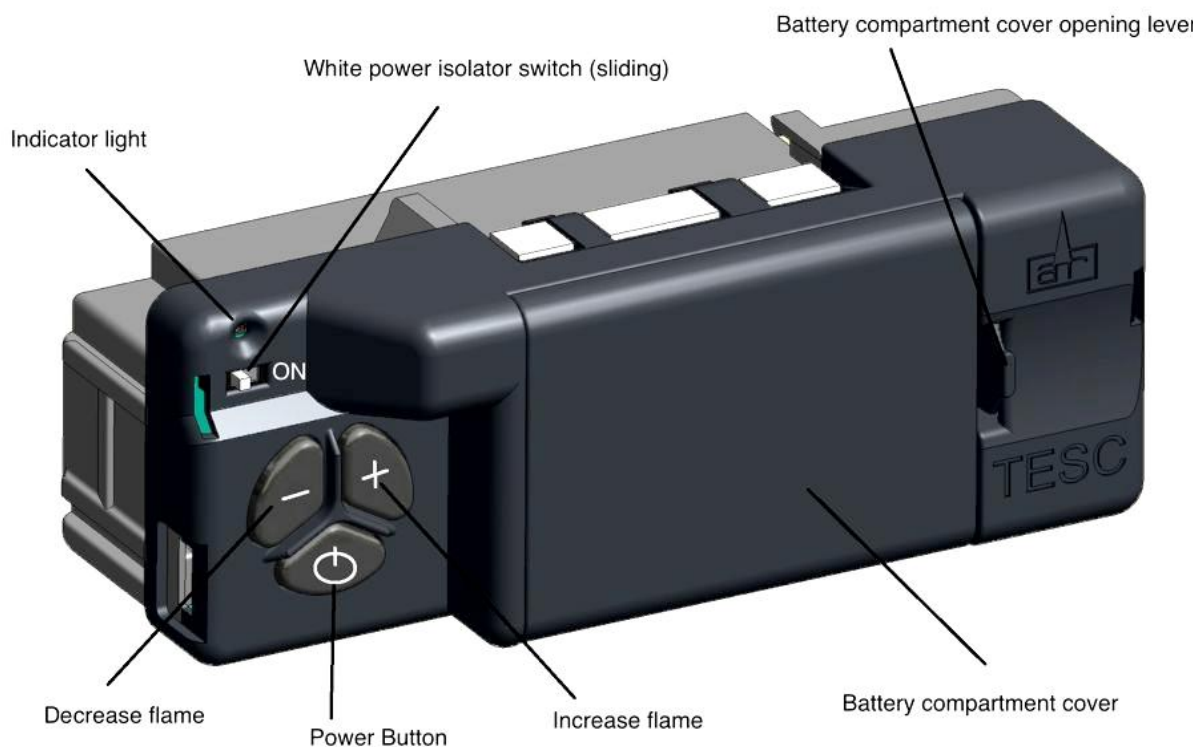

After fitting the batteries and replacing the cover the fire can now operate. Slide the slide switch to the right to the ON position.

To start the fire, press the power button and hold for 1 second then release. The burner will within around 1 to 2 seconds, adjust to the maximum power setting,

The power of the burner can be adjusted up and down by pressing the – or + buttons.

To stop the fire, simply press the power button again and the burner will stop.

If you are not intending to use the fire for a long period (i.e. over summer time months), the battery life can be extended even more by sliding the white isolator switch to the left (away from the on position).

**Ensure the very small white slider switch on the front corner of Fire Control is in the on position.**

**Grasp around the handset to unlock its functions. The green unlock light will illuminate to show when the handset is unlocked and ready to accept commands. (N.B. Keep a grip of handset to keep it unlocked, to continue to operate the command buttons.)**

For your safety, the fire is fitted with a Flame Supervision Device (FSD), which will shut off the Gas supply if for any reason the pilot is extinguished.

## The Valve and Handset Have Already Been Paired

First set up the hand set, cup the handset **the green unlock light will illuminate**. Keep it held to keep the control unlocked, to enable operation of the buttons.



**3) Setting the time** the display will be as shown, as the time is not set yet and will progress automatically to the next screen shown below.



Note: the indicator at the bottom shows the battery condition of both the batteries in the hand set and in the fire control within the fire.

RC = Remote Control / FC = Fire Control.

The control is designed to get the most out of the batteries but when eventually the display shows they are spent (when the battery indicator is empty, we recommend you change the batteries in the handset before they are flat, to avoid having to re-program the time of day in again. N.B. Pairing is not lost, even if the batteries are removed or flat.

#### **4) Setting the display for 12 or 24 Hour display**

As always when pressing the remote control buttons keep the control held to keep the green light on and therefore handset safety feature, unlocked. The H indicates that it is time to set the timer to either 24 hour

display or 12 Hour (AM or PM) display. Press the + or – button on the handset to toggle between the two settings. When you are ready to confirm the setting you want press the “SET” button to progress to setting the day of the week.



#### **Setting the day of the week**

Press and release the + and – buttons until the correct day of the week is shown on the display.

(Mo = Monday, Tu= Tuesday, We=Wednesday, Th=Thursday, Fr=Friday, SA=Saturday and Su=Sunday).

Press “SET” to accept the day of the week and to progress to setting the Hour of the day.

Note: Whilst doing this setup pressing “SET” advances to the next display and pressing “MODE” will return you to the previous display setting.



#### **Setting the Hour**

Press and release the + or – button to change the hour to the correct hour and press set to store and to move to setting the minute. Repeat this for setting the minutes.



### Setting the temperature display to Celsius or Fahrenheit.

Press and release the + or - button to toggle between C and F.

When the display shows the desired symbol, press and releases the "SET" button to store.

As the important settings above have now been done. Press and hold (not releasing straight away) the "SET" button for a few seconds and this will exit the setup menu.

The control is now ready for use with the Fire Control.



### Quick start user instructions

First set up the hand set, cup the handset **the green unlock light will illuminate**. Keep it held to keep the control unlocked, to enable operation of the buttons.



Then with the other hand touch and keep you finger on the power button for about 5 seconds. (Upon touching the power button the green light will do a **single flash** to show command is recognized – after 5 seconds the green light will flash for a second time, at which you should release your finger). The Fire should be lit within a few seconds. (N.B. If power button is held for more than a few seconds after second flash/beep, the command ignored for safety reasons. With this system, the control has been designed to ensure that only intended ignition of the fire occurs.)

To stop – with handset held to unlock it, press then release power button.

Mode  
Man = Manual  
Zzz = Snooze  
Therm = Thermostat  
Timed

In Range of the fire  
If missing out of range or fire switched off

Day of the Week

Time (12 or 24hr)

Fire Status

Battery Indicator  
RC = Handset  
FC = Fire Control

Light Sensor (for Display Backlight)

To Change Mode

Press to Decrease

Power Button



Room Temperature

Handset Unlocked if Illuminated

To Change Settings see handbook

To Increase Flame



## Operating instruction (Detailed)

**1)** Upon successful insertion of the batteries in the Handset (if the handset has not previously paired) the display will be as shown if it has been paired already then go to No 3.



**1a)** if display is not as above the handset may well need to be reset before pairing.

Press and Hold "Set" Button, to enter Programing menu

When Set Up is flashing, press and release set to enter Setup Mode.



Press and Release the "Set" button several times until you see CAO displayed.

Then press and release "+" button once to change display to CA1

Press and Release the "Set" button once more to display TESC, handset is now ready to pair.

## **2) Pairing the Handset to the Fire Control** (paired at factory only do if re-pairing)

- After fitting the batteries as above (and with the isolator slide switch on the TESC Fire control in the ON position), simultaneously press and hold the – and + buttons on the fire control (i.e. not the handset) 5- 10seconds – then LED on TESC lights – then within 2 seconds of LED light coming on, press the power (start stop ) button on TESC.
- The handset will beep and green light flash



Hold the handset in one hand so your fingers wrap around the back of the operating buttons area of the handset. A green unlock light will illuminate when the handset has detected your hand. The green light must be illuminated in this way for any of the command buttons to accept commands to operate the fire

control. Whilst the display is as shown, and holding the handset as described, press the "SET" button with the other hand to finish off the pairing of the handset to the Fire Control and to enter to setup the time of day on the handset. N.B. If the display returns to the one shown above with the word "TESC" shown, then too much time has passed before pressing "SET" and so the handset has not paired yet. Simply repeat pairing again.

Video available on **You Tube** Search for; **TESC Gas Control - Display handset pairing**

### **Advanced settings Menu**

In the event that you may want to change the other pre-set settings of the control features. Do not do a long press and hold above but a normal short press and release will take you into the advanced settings area.

Advanced settings options are:-

- Back light –
  - o A = Automatic (default setting). The back light comes on in the dark but not in the light.
  - o 0 = Light never comes on.
  - o 1 = Light comes on whenever handset is unlocked.
- Display contrast – 8 levels from 0 to 7 (default level 4).
- P = pairing with other devices other than the fire control.

The hand set can pair with other modules to:-

- o L= Operate an electric light – which is the dimmable in 9 steps
- o F= operate an electric fan –which can have 9 speed levels
- o A= operate an auxiliary contact to operate another device.

## **CLEANING**

Before carrying out any of the following operations, ensure that the fire is OFF and completely cold.

Debris that may form on the fire bed should be periodically removed by a competent person.

Large deposits could indicate deterioration of the flue. This should be repaired by a competent person, and the fire serviced before further use.

PAINTED AREAS - These can be cleaned using a dry cloth.

COALS AND CERAMICS: See the relevant section in the Installation Guide of these instructions.

SERVICING: The fire and flue should be checked on an annual basis to ensure all of the products of combustion are entering the flue and that there is no excessive build-up of soot.

The frequency of service will depend on usage, but **MUST** be carried out at least once annually. Servicing must be carried out by a competent person, such as a Gas Safe registered installer.

Cleaning of the coals may be carried out by following the instructions given in the Installation section.

The Installation instructions carry full servicing details for the use of the installer.

If debris from the flue or other foreign matter is found on the fire it may indicate a need for servicing.

Do not use the fire until the source of the debris has been found and rectified.

Air vents (where fitted) should be checked periodically to ensure they are free from obstruction

## SECTION 19: LIST OF SPARES

6 MODEL							
CODE	SPARE PART DESCRIPTION	PARTNUMBER					
3F	GRAVEL GREY	CER	G	ROY	6	GRY	
	GRAVEL BLACK	CER	G	ROY	6	BLK	
2F	BURNER GRANUALS	CER	GRT	ROY	6	GRY	
1B	ENGINE EXCLUDING CERAMICS	ROYS	6	N	RC	ENGINE	
6E	REMOTE HAND SET	VAL	RC	UN	RH	THERM	5
7E	Tesc 01-RF868-15 Valve	VAL	RC	UN	VAL	THERM	6
12E	PILOT NG Thermaco NG OXI-PG-82-460	PRT	VAL	PI	RO	PL	Therm
1A	GAS INLET TUBE 8MM REMOTE	VAL	TU	ROYS	6	SI	2
A2	PILOT GAS TUBE 4MM REMOTE	VAL	TU	ROYS	6	SI	3
A3	VALVE / BURNER TUBE 8MM REMOTE	VAL	TU	ROYS	6	SI	4
4A	BURNER TUBE REMOTE	VAL	TU	ROYS	6	SI	1

10 MODEL							
CODE	SPARE PART DESCRIPTION	PARTNUMBER					
5F	GRAVEL GREY	CER	G	ROY	10	GRY	
	GRAVEL BLACK	CER	G	ROY	10	BLK	
2F	BURNER GRANUALS	CER	GRT	ROY	10	GRY	
1B	ENGINE EXCLUDING CERAMICS	ROYS	10	N	RC	ENGINE	
6E	REMOTE HAND SET	VAL	RC	UN	RH	THERM	5
7E	Tesc 01-RF868-15 Valve	VAL	RC	UN	VAL	THERM	6
12E	PILOT NG Thermaco NG OXI-PG-82-460	PRT	VAL	PI	RO	PL	Therm
1A	GAS INLET TUBE 8MM REMOTE	VAL	TU	ROYS	10	SI	2
A2	PILOT GAS TUBE 4MM REMOTE	VAL	TU	ROYS	10	SI	3
A3	VALVE / BURNER TUBE 8MM REMOTE	VAL	TU	ROYS	10	SI	4
4A	BURNER TUBE REMOTE	VAL	TU	ROYS	10	SI	1