

# Apex Adara HE

## Installation and User Instructions

All instructions must be handed to user for  
safekeeping

This is not a DIY product and must be installed by a  
Gas Safe registered installer

Edition D 09/15

Country(s) of destination - GB/IE

**Please ensure you read both the Fire and the Fascia  
instructions before starting the installation.**

## INSTALLATION INSTRUCTIONS

### These Notes Must Be Read Before Installation

This appliance is an Inset Live Fuel Effect appliance that provides radiant or combined radiant and convected heat; it cannot and **should not** be used as the main heating source within a property.

The appliance is designed to fit most types of fireplaces with a natural draught flue as listed in the Installation Requirements.

The appliance must be installed by a competent person in accordance with the Gas Safety (Installation and Use) Regulations 1998.

A Gas Safety Registered installer must be used for this purpose.

Read all these instructions before any installation takes place and in conjunction with the appliance on site.

This appliance must be installed in accordance with the rules in force and only used in a sufficiently ventilated space.

This appliance is factory set and tested for operation on the gas type, and at the pressure stated on the appliance data plate.

After a new gas appliance (excluding flueless cookers) has been fitted, the Building Regulations in England and Wales require that the installation must be notified to your Local Authority. Your Gas Safe registered engineer needs to do this, failure to register the appliance may affect your warranty.

## OPENING THE APPLIANCE

Stand the carton the right way up, open the box from the top.

To remove the appliance lift by the handle secured to the top.

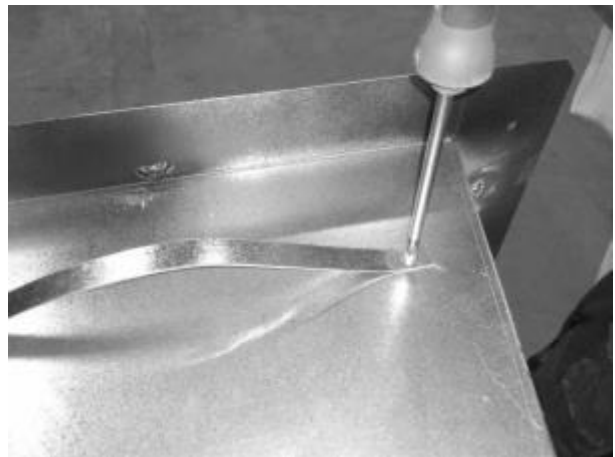

Once the appliance is out of the carton remove the handle and replace screws back in the holes

Read all the instructions before continuing to unpack or install this appliance.

Remove the bags containing ceramic components such as coals or gravel etc. Remove the cardboard packing pieces, and any other bags or boxes containing fittings or other parts, when all loose parts have been removed, the appliance may be lifted from the outer carton.

Check that the components supplied correlate with the component checklist below.

If for some reason any of the listed components are missing or damaged do **NOT** commence with this installation, in doing so will invalidate your warranty.

Please dispose of all the packaging materials at your local recycling centre.

## CONTENT CHECK LIST

Quantity	Description
1	<b>Firebox and Burner Tray</b>
1	<b>Decorative Trim/Frame</b>
1	<b>Fire Fret/Front</b>
1	<b>Rear Matrix/ Fuel Bed support</b>
1	<b>Front Matrix/ Fuel Bed support</b>
1	<b>Coals/Pebbles Bag of (9 or 14)</b>
1	<b>Ceramic brick panel.</b>
1	<b>Cable fixing kit; 1 cable, 2 tensioners, 2 cable clamps, 3 fixing eyes.</b>
1	<b>Lengths of adhesive sealing strip.</b>
1	<b>Set of manufacturer's instructions and warranty card.</b>
3	<b>Raw Plugs</b>

## INSTRUCTION CONTENT

Section	Contents	Page No
1	Important Notes	5
2	Installation requirements	6
3	Appliance Information	7
4	Ventilation	8
5	Site Requirements	8 to 9
5.1	Pre-Fabricated Flue box	10
6	Debris Space	11
7	Installation of appliance	11
7.1	Preparing the Opening	15
7.2	Fitting the Burner Tray	18
8	Fuel Bed	21
9	Fitting The Outer Frame/ Trim	22
10	Commissioning the Appliance	23
10.1	Spark Failure	23
11	Setting Pressure	23
12	Spillage Monitoring System	24
13	Testing for Spillage	24
14	Briefing the Customer	25
15	Servicing	26
16	Cleaning the Coals	26
17	Troubleshooting Guide	27
18	User Instructions	28
19	List of Spares	32

## Section 1: IMPORTANT NOTES

This fire is an Inset Live Fuel Effect Gas Fire providing radiant warmth. It is designed to operate on Natural Gas or LPG.

It is the LAW that all gas appliances and fittings are installed by a competent person such as a Gas Safe Registered fitter and in accordance with the Gas Safety (Installation and Use) Regulations 1998, the relevant British Standards for Installation, Codes of Practice and in accordance with the manufacturers' Instructions.

The installation shall also be carried out in accordance with the following regulations:

The Building Regulations issued by the Department of the Environment, the Building Standards (Scotland) (Consolidation) Regulations issued by the Scottish Development Department.

BS 1251

BS 4543 part2

BS 5440 parts 1&2

BS 5871 part 3

BS 6461 parts 1&2

BS 6891

BS 8303

Failure to comply with these regulations could lead to prosecution and deem the warranty Invalid.

This appliance must be installed in accordance with the rules in force and used only in a sufficiently ventilated space.

Consult all instructions before installation and use of this appliance.

The appliance must be registered once commissioned with the regulatory governing body.

This appliance is free from any asbestos material. Refractories and coal bed are constructed from ceramic fibre.

**Note - For Republic of Ireland, reference should be made to the relevant standards governing installation, particularly in regard to flue sizing and ventilation. See IS813, ICP3, IS327 and any other rules in force.**

## Section 2: INSTALLATION REQUIREMENTS

This appliance **MUST NOT** be installed into a bathroom or shower room, or where steam may be present.

An extractor fan must not be fitted in the same room or space as the appliance as this can affect the safety of the appliance.

The fire has been designed to fit into a fireplace or builders opening conforming to BS 1251 (and meeting certain dimensional requirements), or a suitable flue box complying with the constructional requirements of BS 715.

A natural draught flue system is required, and if previously used for solid fuel or oil burning, the flue and chimney must be swept prior to appliance installation.

The flue must be checked before installation by using a smoke pellet or similar to ensure proper draw and that leakage is not evident at any joints. Repair and re-test as necessary before the appliance is installed.

Any flue box used must be installed onto a suitable non-combustible insulating surface at least 12mm thick, covering the entire base area of the box.

The flue must have an effective height of at least three metres, as measured from the hearth to the top of the flue.

Any flue damper plates or restrictors must be removed and no other restriction fitted to the flue. Where removal is not practical, the restriction must be fixed in the fully open position.

The flue must be connected to only one fireplace, and the flue must not vent more than one appliance.

There must be no opening in the flue apart from the one that the appliance is installed into, and the one venting the gases into the air. A suitable terminal may be fitted, such as class GC1, as regulations allow.

Some of our appliances have been tested for use in a pre-cast block flue complying with BS 1289.

In accordance with BS1289 part 1, pre-cast flues built with directly plastered faces (front or rear) are not correctly installed as to ensure proper operation with any type of gas fire.

Depending on the flue construction, on occasions the temperature reached can cause cracking of the surface plaster through no fault of the appliance.

An air gap or some form of insulation material should be installed to prevent normal flue temperatures from damaging wall surfaces.

This appliance is suitable for use with a surrounding area or back panel of 150C minimum rating.

## Section 3: APPLIANCE INFORMATION

Gas Group	G20 Natural Gas CAT I2H
Inlet Pressure	20 mbar
Max Input (gross)	5.3
Min Input (gross)	3.2
Setting Pressure	20 mbar
Gas Inlet connection	8mm Compression
Overall Height	596
Overall Width	500
Overall Depth	252
Recess Height	555
Recess Width	382
Recess Depth	250
Air Vent	N/A
	<b>Manual</b> Thermaco NG
Pilot Assembly & Thermocouple	OXI-PG-82-460
Valve	SEAGAS V4-78A A13
Injector	STEROMATIC 360

## Section 4: VENTILATION

This Appliance does not normally require purpose provided ventilation. However, a second appliance operating within the same room or space must be taken into consideration when assessing ventilation.

When commissioning the appliance spillage is detected, then amongst other problems there may be insufficient natural ventilation for correct operation of the flue. If spillage is detected with windows closed, but the appliance does not spill with the windows open, this demonstrates a lack of natural ventilation.

If spillage is still detected with the windows open, the flue is at fault. Installation of an air brick is the best solution to lack of ventilation.

Any ventilation fitted must comply with BS 5871 part 2 and BS 5440 part 2.

Air Vents fitted under or within the immediate vicinity of the appliance must not be used as adverse effects to the operation of the Flame Safety Device (FSD) may occur. Spillage detected during commissioning is almost always a result of poor flue performance that cannot be corrected by any amount of ventilation.

***For Republic of Ireland ventilation may be required, see IS 813, ICP3, IS 327, and any other rules in force.***

## Section 5: SITE REQUIREMENTS

The fireplace opening should be inspected and repairs made where necessary.

A chair brick or fireback may be left in place, providing that the dimensional requirements for debris collection space and spigot clearances are met. See diagram below.

This appliance requires a natural draught flue system which may be one of the following;

225mm x 225mm (9in x 9in) brick or stone

125mm (5in) minimum diameter lined brick or stone.

125mm (5in) minimum diameter twin wall flue must conform to BS 715.

Any existing draught device situated under the fireplace must be sealed off. The opening area must be non-combustible. The appliance requires a hearth with non-combustible surface of at least 300mm in depth and 12mm thick.

The top surface must be at least 50mm above the surrounding flooring level, or be surrounded by a raised edge or fender 50mm high. To enable the product of combustion to be cleared properly up the flue, the outlet at the back of the appliance must have a 50mm minimum clearance between it and the back wall of the opening or any other obstruction, the area immediately above the outlet must form a smooth path into the flue.

The fireplace or builders open must be reduced to suite the appliance both side to side and the full depth of the appliance, a decorative back panel i.e. marble, granite etc. must not be used as a closure plate for the appliance please see below.



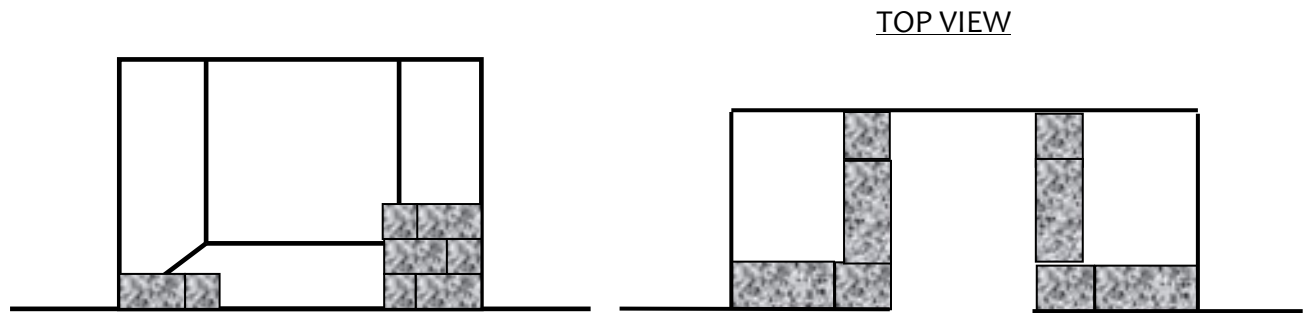

Any type of fire surround used with this appliance must be adequately sealed to the wall and floor; a combustible shelf may be fixed to the wall above the fire, providing that it complies with the dimensions given below.

From Hearth to Underneath of Shelf with a depth of 150mm is 800mm add 12.5mm in height for every 25mm increase to the projection of the shelf depth.

Any combustible side walls must be at least 500mm to the side of the radiant heat source, as with all heating appliances, any decorations, soft furnishings, and wall coverings (i.e. flock, blown vinyl and embossed paper) positioned too close to the appliance may discolour or scorch.

**Due to the high efficiency of this type of appliance combined with the variations of plaster conditions and thicknesses from property to property, we recommend that a heat proof plaster be used.**

**An area of 600mm above plus 300mm on either side and below should be finished with a heat proof plaster, it may be required to use a heat proof screed under the finish, please see contact details below of possible supplies of these goods for your reference.**

**The Greener Company**

Huddersfield Road, Elland, WEST YORKSHIRE HX5 0EE

[www.thegreenercompany.com](http://www.thegreenercompany.com)

**Vitcas**

8 Bonville Road, Brislington, Bristol BS4 5NZ

<http://www.vitcas.com>

**Diagram 1**

Adara HE		MM
A	Height	555-575mm
B	Width	382-415mm
C	Depth	250
D	Minimum Hearth Depth in Front of the Fire	300mm
E	Heath must Extend Minimum of	150mm
F	Minimum Hearth Height	50mm

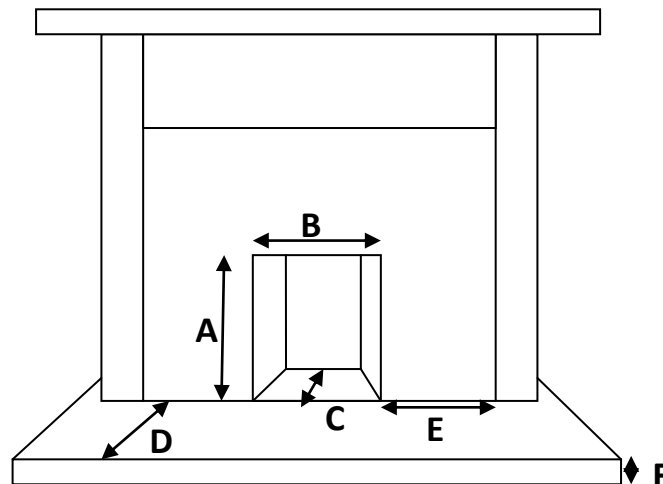

### **Hole-in-the-wall installations**

Where the appliance is to be installed as a hole-in-the-wall fireplace, a hearth as previously detailed for floor level fireplaces shall be fitted on the floor beneath the hole so as to protect combustible material from heat.

However, if a hearth is not to be used, so as to maintain a minimal and contemporary look, the appliance must be installed so that every part of any naked flame or incandescent part of the fire bed is at least 300mm vertically above any carpet or floor covering.

When no hearth is to be fitted consideration must be given to fixing a tactile barrier to protect young children, the elderly and the infirm.

A tactile barrier can be in the form of a fender, kerb, hearth, shelf or horizontal bar all made from non-combustible material and fixed not less than 50mm & not more than 1000mm above the floor level. They should be positioned not less than 300mm in front of the appliance.

## Section 5.1: PREFABRICATED FLUE BOXES

This appliance can be fitted into a number of flue boxes provided that the minimum dimensions required for the appliance complied with. The frame of the fire, any back panel or other infill panels, and the flue box must be sealed together so that there is no possibility of leakage between them.

The correct clearances to combustible materials (i.e. false chimney breast etc.) must be adhered to. The manufacturers' instructions for fitting the prefabricated box must be complied with at all times.

To fit the fire using the cable fixing kit supplied, some minor adaption may be necessary for certain flue boxes. Please ensure the firebox does not obscure the flue box outlet.

The firebox, base of the flue box, and hearth below may be drilled to allow plugs and screws to secure installation. It is important that the sealing requirements of the appliance are met at all times and that the flue box is sealed to any back or infill panel.

Note: The DEPTH dimension is inclusive of any back or infill panel.

## Section 6: DEBRIS SPACE

In accordance with BS 5871 part 2, minimum debris collection volumes are required behind the installed appliance.

CLAY/CEMENT LINES OR BLOCK FLUE WHICH IS NEW, UNUSED, OR PREVIOUSLY ONLY USED WITH A GAS FIRE.

### **Appliance recessed depth + 20mm**

UNLINED FLUE OR CHIMNEY WHICH HAS BEEN PREVIOUSLY USED FOR A SOLID FUEL OR OIL BURNING APPLIANCE

### **Appliance recessed depth + 60mm**

## Section 7: INSTALLATION OF THE APPLIANCE

Always ensure that the gas supply is isolated before commencing installation of the appliance.

The fireplace opening and environment must be in compliance with specifications laid down in the appropriate sections of these instructions.

Remove the appliance from its carton as described previously and stand on a dust sheet, place the coals, ceramics and fixings safely to one side.

Remove the burner from the assembly by removing the two screws at the base of the burner tray and undoing the connecting nut to the isolation tap.

Unsecure the glass panel from the box as shown below, Remove outer cover to the glass Panel.



Remove the manual burner from the assembly by removing the two screws at the base of the burner tray and undoing the connecting nut to the isolation tap.

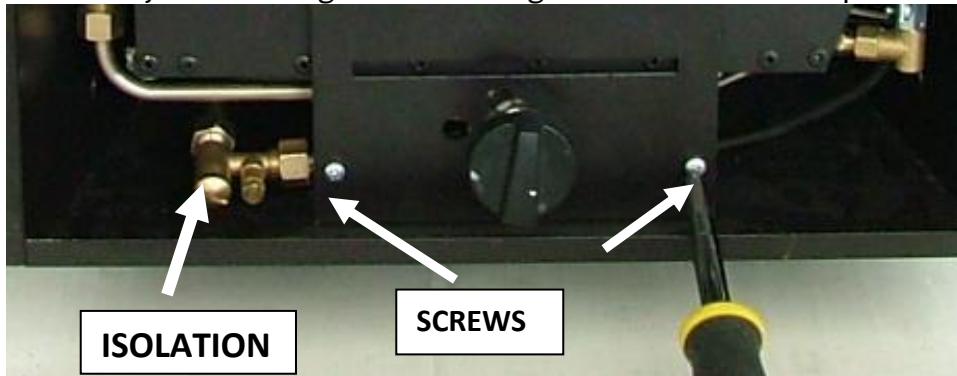

Now, remove the 2 screws on the top of the burner tray.



The tray is now free and may be lifted away from the box, lift free of the firebox.

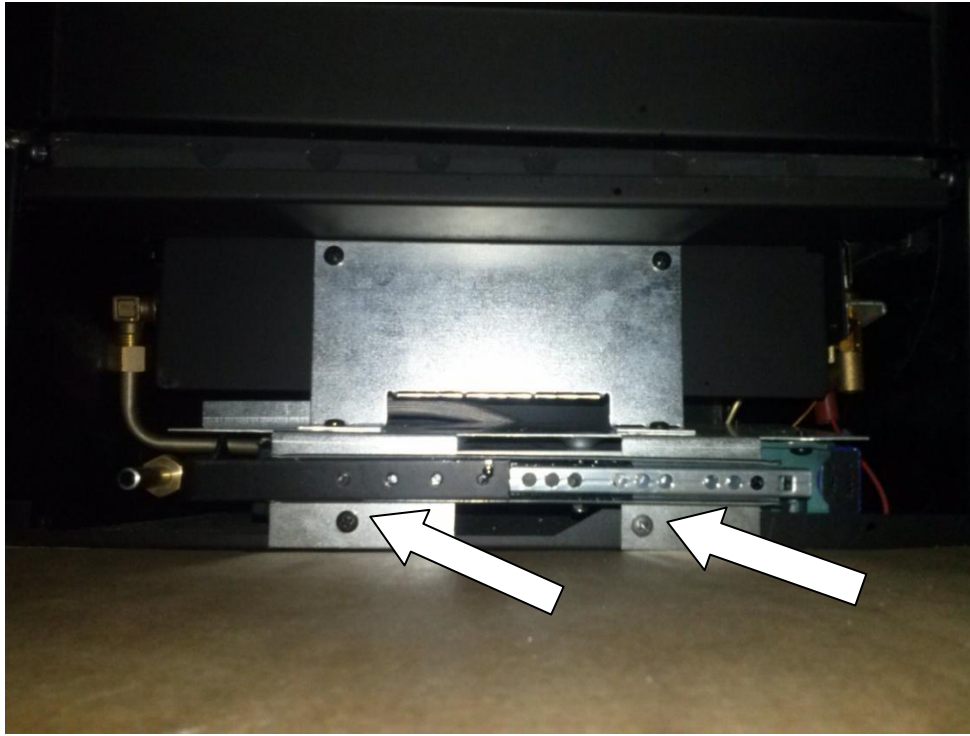

Remove the 2 screws on the top of the burner tray.



The tray is now free and may be lifted away from the box, lift free of the retaining clips on each side of the burner tray.

## Diagram 5



You can now decide where to route your gas pipe, knock out holes are provided in the rear and side of the fire box for use where concealed pipe work is required.

Knock out the holes with a screwdriver and a sharp tap from a hammer and fit the rubber grommet supplied.

The position of the isolation tap may change depending on the model being fitted.

***Note: DO NOT install or use the appliance without this seal in place, Failure to fit this seal correctly will cause the flue suction to act upon the area under the burner tray resulting in poor performance, and overheating of this area.***

## Section 7.1: INSTALLATION OF THE FIREBOX

Before installing the fire, check the flue for correct operation using a smoke pellet, all of the smoke should be drawn up the flue and exit correctly from the terminal.

If problems are found **DO NOT** fit the fire until corrective measures have been completed. Protect the decorative hearth whilst pushing the convector box in and out of the opening. Part of the packaging or a dust sheet can be used.

Before running the gas supply into the opening, offer up the convector box to the fireplace to check the fit is good. Ensure that it slides in correctly, the sealing face sits flat and square to the wall or back panel, and that the base level with the hearth as no leaks are permissible here.

At this stage it is essential to ensure that the spigot outlet of the fire is not obstructed in any way. Remove the fire box and apply the self-adhesive sealing strips around the edge of the rear of the firebox frame, approximately 5mm in from the edge.

### CABLE FIXING:

Using the template provided, place this within the opening with the bottom edge of the template level with the hearth.

Drill 4 x 6mm holes through the template as shown in the diagram and fit the Rawlplugs and screw eyes supplied.

**Diagram 6**

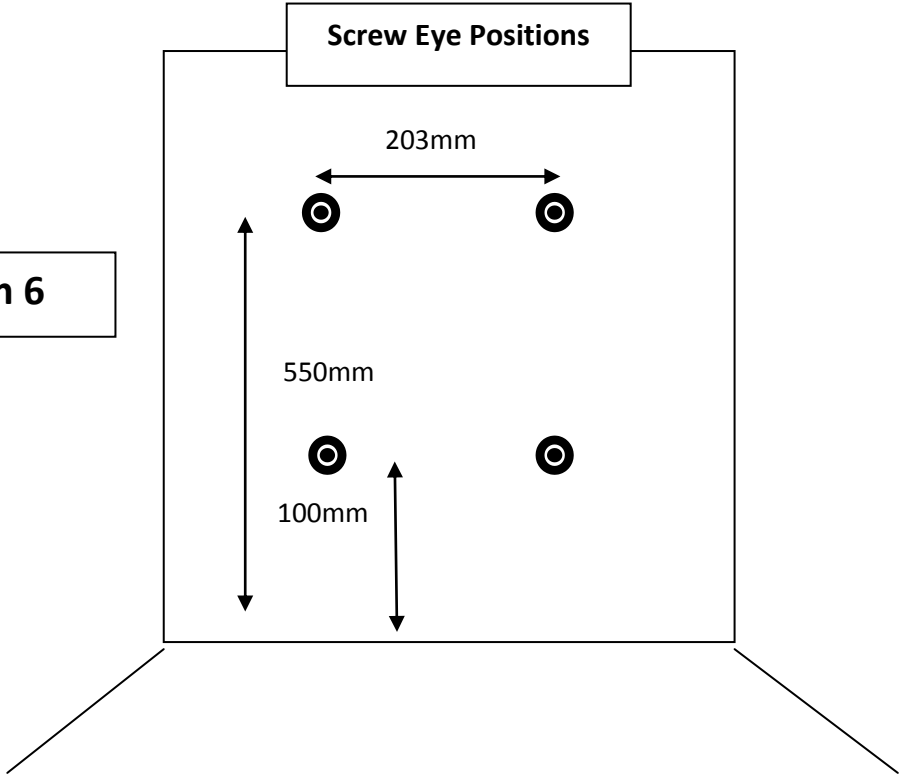

**Note:** In some instances the plastic Rawlplugs supplied may need to be substituted with fibre rawlplug's, if the appliance is likely to heat the screw eyes.

If the fireplace does not allow for the exact layout shown, the eyebolts should be fixed to give a similar configuration as possible.

Thread the tensioning cable through the holes at the top of the firebox, then through the two screw eyes in the top position and then through the one at the lower position, back through the lower hole in the firebox as shown in the diagram.

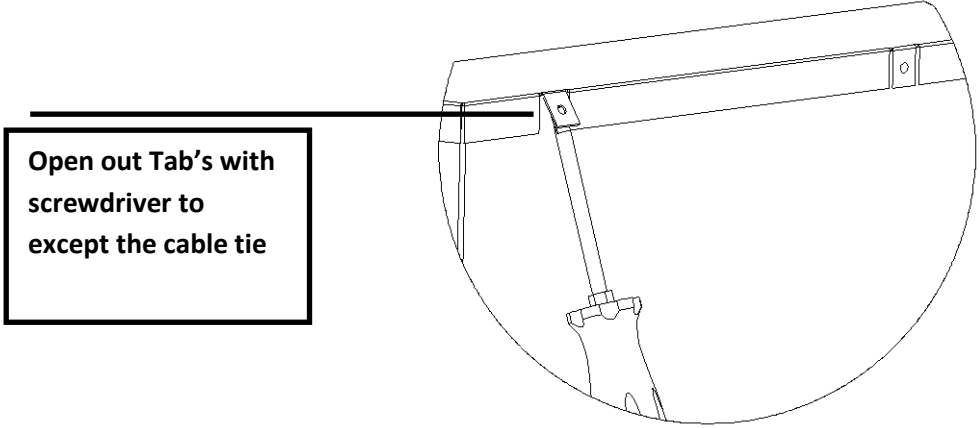

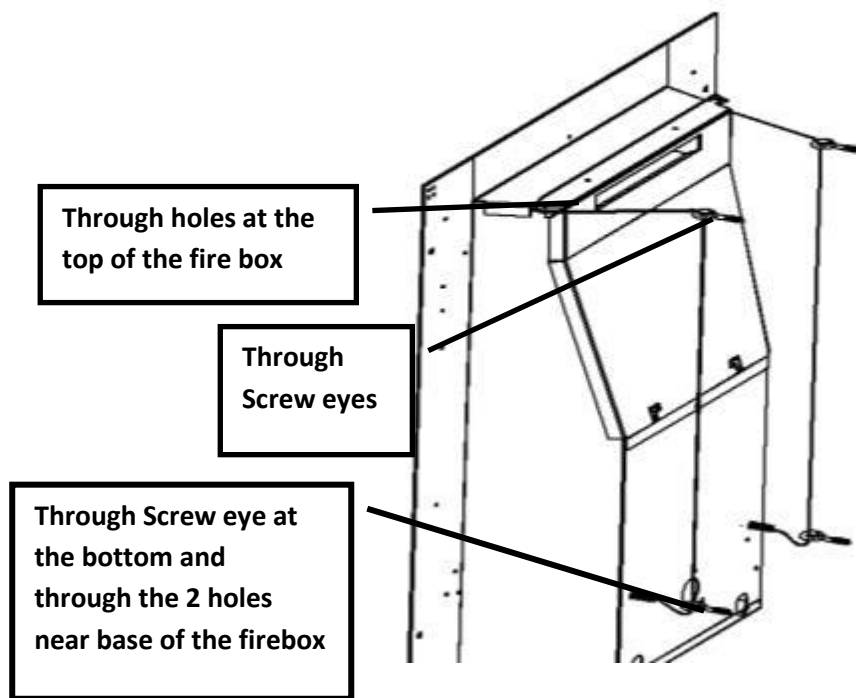

Push the appliance back into the fireplace, centralise and pull the loose cables through the holes into the firebox, thread the cable tensioners onto the cable as shown, with the nuts screwed down close to the tensioner head. Slide the screwed nipple through the box and pull cable taut and tighten pinch screw on to the cable.

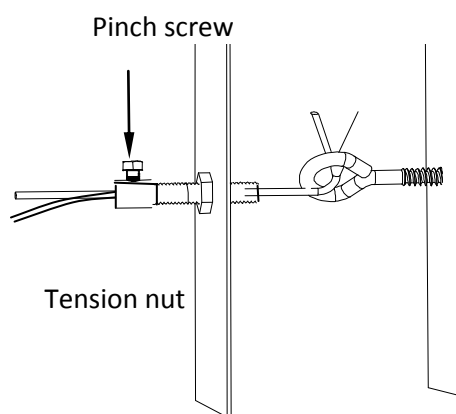

Adjust tensioner using a suitable spanner to pull the cable tight into position, to allow an even seal around the edge of the fire, visually inspect the seal and reseal if necessary.





Surplus tension cable **MUST NOT** be cut off as this will prevent proper installation after servicing simply coil up the surplus cable as shown and tuck the coils out of the way.

#### **Fixing by screw:**

Mark and drill the fire frame or base, and relevant points in the opening or on the wall. Raw plugs will be required.

**Note:** *Fibre Rawlplugs might be preferred rather than plastic Rawlplugs as the heat from the fire might affect their efficiency.*

Whilst the opening is ready for installation of the fire, the gas supply can be routed as required and connected to the isolation tap via the 8mm compression fitting.

**Note:** *In no circumstance should you use soft soldered connections to or underneath the burner tray.*

## **Section 7.2: FITTING THE BURNER TRAY**

Temporarily fit the burner tray and ensure a suitable gas route can be achieved.

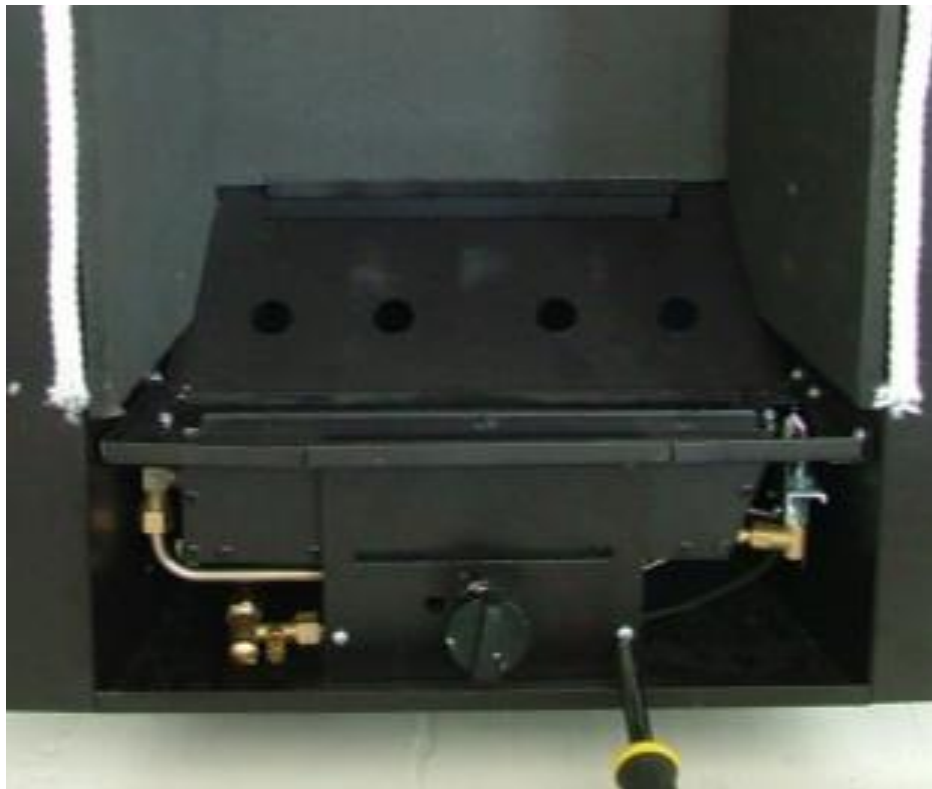



If the fire is the manual control system, you can now place the burner tray into the firebox making sure that the fixing points are located properly on the firebox.



Fit the two securing screws through the front plate ensuring that the plate is in correct position in the box; secure the two screws at the back of the tray. Connect the gas supply and tighten the gas connections.

## Section 8: FUEL BED LAYOUT

Place the ceramic middle matrix onto the burner ensuring that it sits flat on that base plate and the front is behind the burner.



Place the rear matrix behind the middle matrix and again ensure it is sitting flat on the base plate of the burner.



Place front matrix coal support into the front shelf support brackets.



Place the front row of 6 coals between the front coal support and the middle matrix as shown.

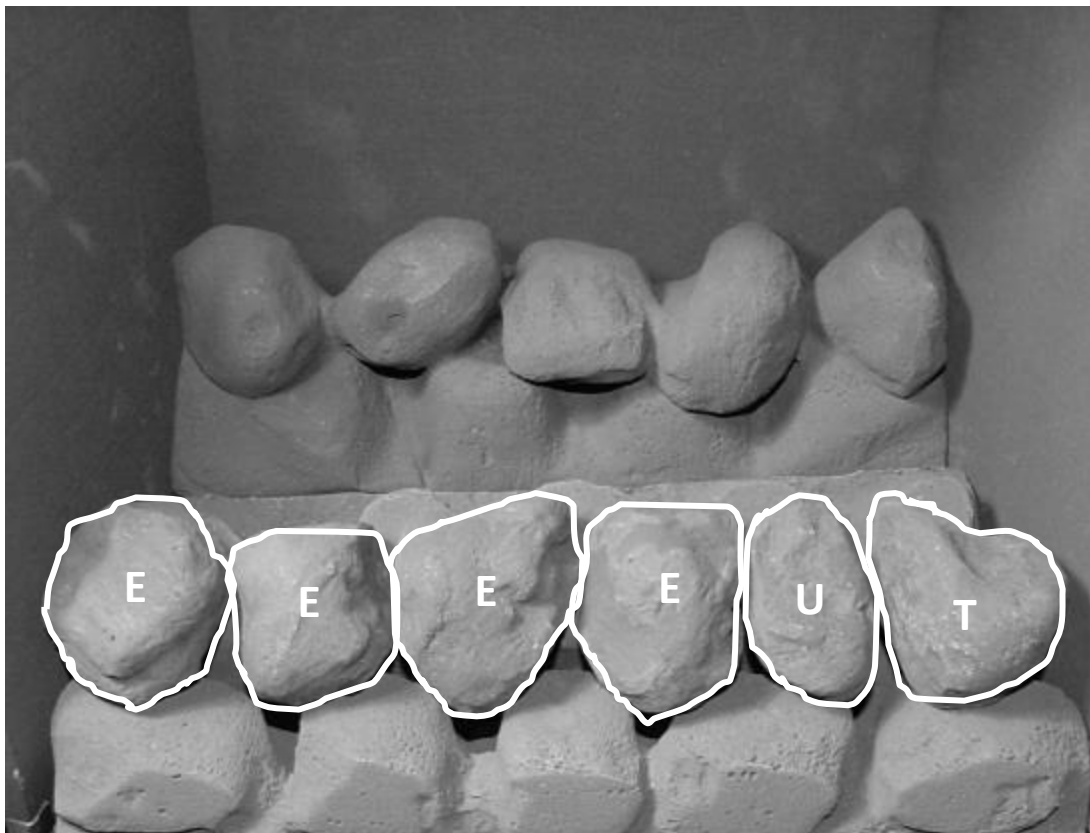



Now Place the second row as shown below.

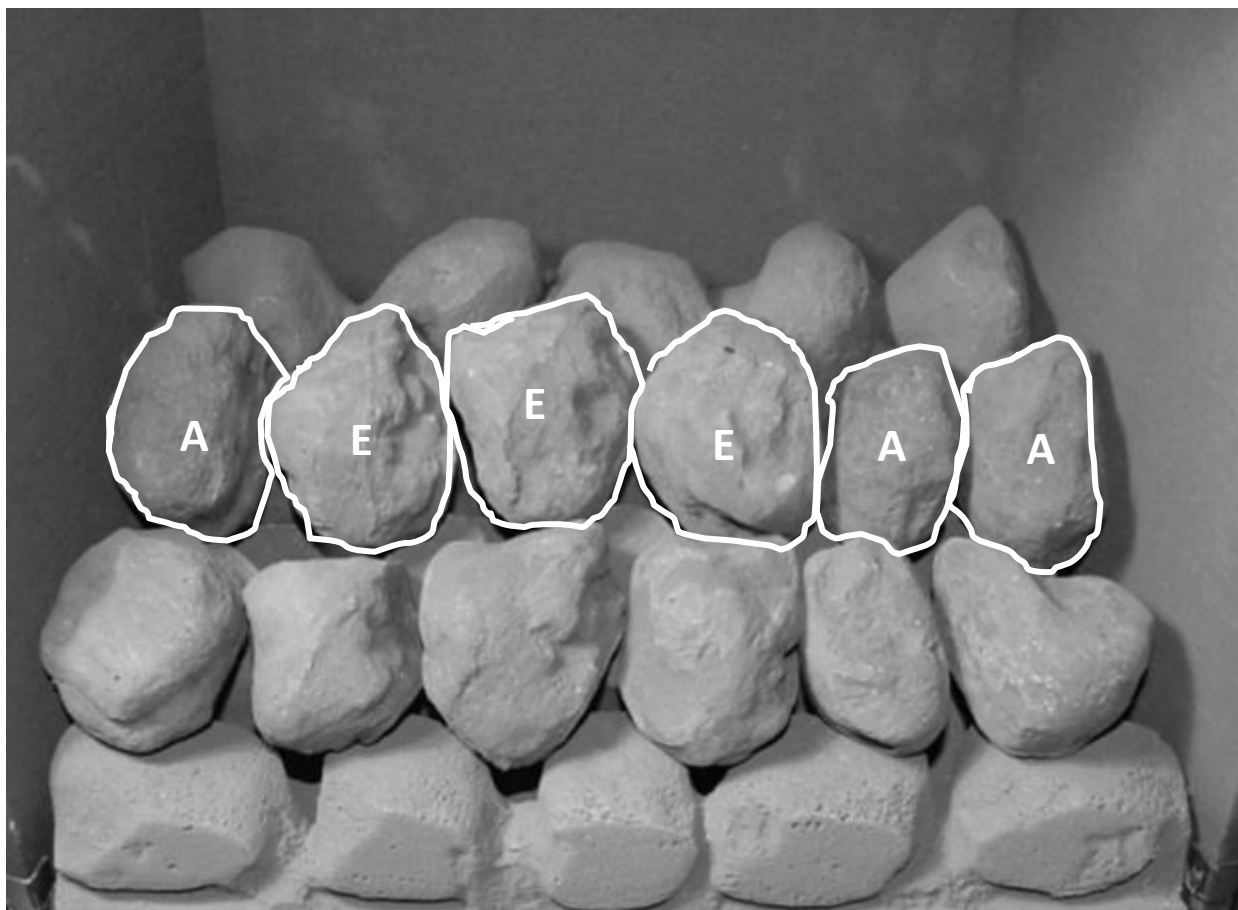

Note: The coals must not be crammed together, or inserted into the holes in the matrix,

Pay special attention to finally adjust the coals with the fire lit on the HIGH setting in order to ensure that no flames play onto the firebox sides or glass, you may need to place the glass in position and then make the final adjustments to obtain equal flame picture without touching the glass.

The Coals/Pebbles **MUST** be placed, sitting on-top of the front ceramic resting between the pillars of the floor matrix, (as shown in [fig 1 and photos](#)

This allows the flame path to take its correct direction.

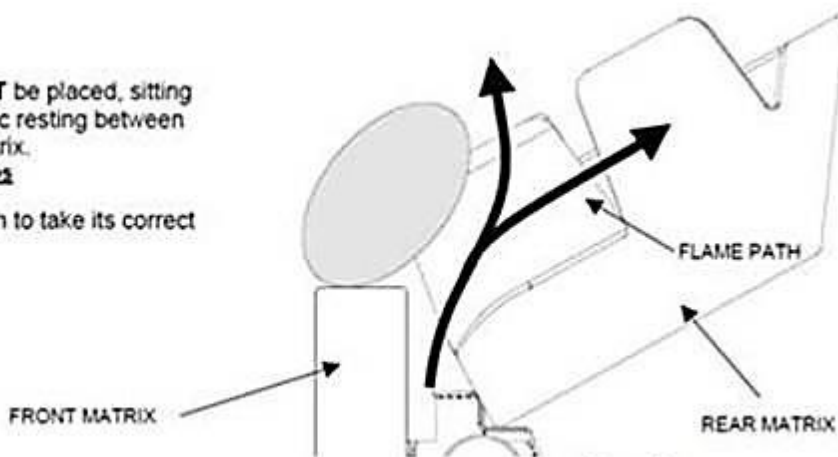

## Section 9: FITTING THE DECORATIVE FRAME

The appliance is supplied with a standard decorative frame, the frame attaches to the firebox as a three piece or one piece clip-on unit. Place the magnets supplied to the outer frame of the fire box.

A plastic protective coating may be applied to the face of the frame assembly, which should be removed at this stage; the one piece unit can be placed in position, with the three piece unit you should start with the side pieces of the clip-on assembly, these should be pushed into position first, followed by the top bar, which should overlap the sides.

**IMPORTANT NOTE: Due to the possibility of sharp edges, care should be taken when handling the three piece frame components, the use of protective gloves is recommended.**

Place the fire front/ fret into position in front of the fire and slide the ashpan door into place. The fire front/fret shown in these instructions may differ from the one supplied with the appliance, we strongly recommend you use a fire front/fret supplied by Sirocco fires as these products will have been tested with the appliance, although other fire front/frets will be compatible.

**You may have an alternative design of fascia please refer to the instructions supplied under separate cover where applicable**

## Section 9: COMMISSIONING THE APPLIANCE

Turn on and test the gas supply up to the fire for any leaks, in accordance with current Approved Codes of Practice (ACOPs)

## Section 10.1: OPERATING THE APPLIANCE

(See Section 18: Users Instructions)

## Section 10.2: SPARK FAILURE

The gap between the spark electrode and the pilot should be 3.5 - 4.5mm to produce a good spark. There should be no need to adjust this.

If under any circumstances the electric spark fails, the pilot may be lit manually by proceeding with the ignition sequence as previously described, and after turning the control knob through the spark position, the knob should be held in and the pilot lit with a taper.

**Note:** Please ensure that the electrode spark igniters' gap on the manual version has not been misaligned during the handling of the burner in this installation the gap should be 5mm from the burner.

## Section 11: SETTING THE GAS PRESSURE

Remove the pressure test point sealing screw from the isolation elbow and attach a suitable pressure gauge.

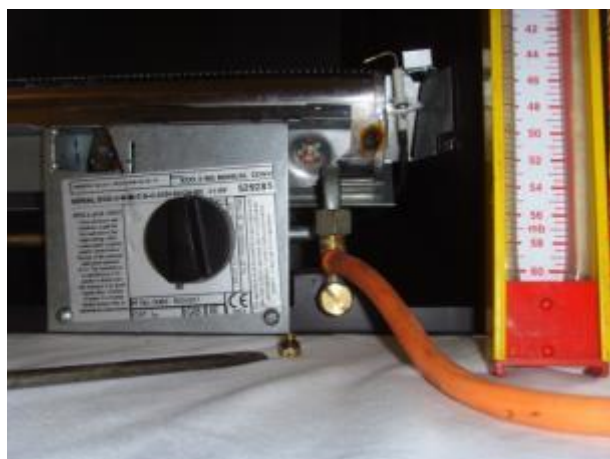

Check that the inlet gas pressure is at 20 mbar / Working Pressure at 20 Mbar (+/- 1 mbar)  
Light the pilot and check the correct operation of the burner at all the flame settings.

Check that the inlet gas pressure is at 20 mbar (+/- 1 mbar), when the fire is at its highest setting.  
Once the fire has been lit for 5 minutes, turn the gas OFF at the isolating elbow.  
After a further 3 minutes turn the gas supply ON again, if the gas has stopped flowing, the Flame Supervision Device (FSD) is operating correctly.

Always check that the gas has stopped flowing even if you hear the FSD valve close within the 3-minute period.  
Turn OFF the appliance and the gas supply and refit the pressure test point sealing screw.

## SECTION 12: FLUE SPILLAGE MONITORING SYSTEM

This fire is fitted with a flue spillage safety device (ODS), if the fire shuts down during use for no apparent reason then several things may be suspected, if a door or window has been opened creating a draught, then pilot disturbance is the problem, and removal of the draught should resolve this.

The gas pressure reaching the fire must also be checked (again, recalls your installer to check and rectify any problem). The thermocouple connection into the back of the gas control valve may also have worked loose during installation, simply get the installer to tighten.

If pilot disturbance is not the cause, then the ODS safety system may be in operation. Switch the appliance OFF, check the flue and carry out any remedial work required. Relight the fire and carry out a spillage test, DO NOT allow the appliance to be used if it continues to fail a spillage test.

The aeration hole of the pilot must be carefully cleaned out on each annual service to ensure continued function of the ODS.

The spillage monitoring system shall not be adjusted, modified, or put out of operation by the installer. Any spare parts fitted MUST be of a type supplied for the purpose by the appliance manufacturer. If the fire is not spilling, then further guidance should be sought, using the Troubleshooting section as a guide.

## SECTION 13: TESTING FOR SPILLAGE

### CHECKING FOR CLEARANCE OF COMBUSTION PRODUCTS

Close all doors and windows in the room.

Light the fire and allow to run for approximately 5 minutes on high position.

After approximately 5 minutes, hold a smoke match just inside and below the centre of the lower front edge of the top of the fire, as shown below in Fig 1.

All smoke generated should be drawn back into the flue, If slight spillage occurs or if in doubt, repeat the test after a further 5-10 minutes. If the test indicates that spillage is occurring and the flue restrictor baffle has been fitted, it should be removed and the test repeated after the fire has cooled, if spillage persists, the flue is not functioning correctly and a fault exists.

If, after investigation the fault cannot be traced and rectified, the fire must be disconnected from the gas supply and expert advice obtained.

After ensuring that the fire is safe to use it should be left on high position to fully warm up. During this time a slight odour may be noticed, this is due to the "newness" of the fire and will soon disappear.



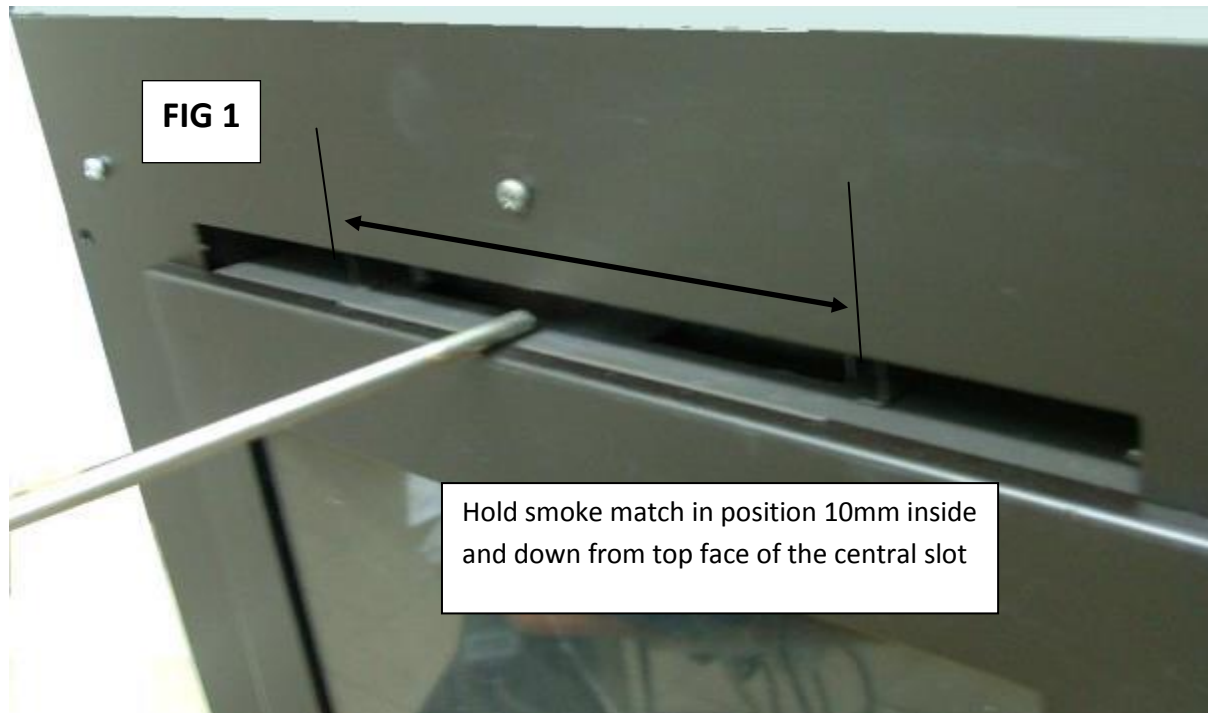

When the test has been completed satisfactorily, repeat with any extractor fans in the premises running on the highest setting, and any communicating doors open.

Finally, repeat with all doors open.

**DO NOT** allow the fire to be used until the test is satisfactorily passed.

## SECTION 14: BRIEFING THE CUSTOMER

- All instructions must be handed to the user for safekeeping.
- Show the customer how to light and operate the fire.
- After commissioning the appliance, the customer should be instructed on the safe use of the appliance and the informed for the need of regular servicing.
- Frequency of service depends on usage, but **MUST** be carried out at least once annually.
- Cleaning of the fire may be achieved when the fire is cold using a damp cloth and mild detergent on most surfaces, with the exception of the ceramic fuel bed.
- A soft brush i.e. paint brush may be used to clean the ceramic fuel bed taken care not to use excessive pressure.
- Scratched and other superficial damage to the matt black paintwork of the appliance can be covered with matching heatproof spray.
- Use only the manufacturers' recommended spray paint.
- Paint only when the fire is OFF and cold. Always mask off the surrounding area to prevent contamination with overspray.
- Ventilate the room during the use of the spray. **DO NOT** attempt to spray paint the coals or ceramics, or wash them in water.
- Advise that the fire will emit a "newness" smell for a time after initial commissioning and that extra ventilation may be needed during this time.
- Advise that the fire is fitted with a spillage safety device (O.D.S.). If the fire shuts down, this system may be in operation.
- If spillage is suspected, **SWITCH APPLIANCE OFF** and call in the installer to investigate any problems.

## SECTION 15: SERVICING

First Isolate the fire from the gas supply and ensure that the fire is fully cold before attempting service.

- Lay out the dust sheet and tools required.
- Remove the cast front fret.
- Carefully remove the ceramic components
- Remove the two screws that retain the tray in place and disconnect from the isolation tap.
- Remove the burner tray and other components as required (i.e. remote control box)
- Disconnect the gas supply, to the appliance and disconnect the isolation tap
- Remove convector box by, firstly protecting the hearth from potential damage, unroll the coiled tensioner cables from the rear of the firebox, remove the securing nipples and tensioner adjusters, the firebox is now released from the opening and can be slid outward onto the hearth.
- Check the fireplace opening for rubble accumulation and remove, if debris is excessive, initiate remedial work on the flue.
- Check the flue with smoke pellet for correct operation.
- Refit convector box using new seals where necessary
- Strip off the burner pipes and clean thoroughly.
- Clean out the injector, pilot assembly and burner tube. DO NOT remove the pilot injector.
- Re-assemble and re-fit the burner tray.
- Turn on the gas supply, and leak test.
- Refit the decorative casting and ceramics.
- Check any purpose provided ventilation is un-obstructed.
- Light the fire and test for spillage.

## SECTION 16: CLEANING THE COALS

- Remove the fire front/fret casting and place to one side.
- Remove the ceramic components.
- Gently clean in the open air using a dry paint brush.
- Be careful not to create dust from the coals.
- Where necessary replace damaged components with genuine spares.
- Seal scrap ceramic components in plastic bags and dispose at proper refuse sites as directed.
- Re-fit the coals by referring to the relevant section of these instructions.

## SECTION 17: TROUBLE SHOOTING

### **Fire sparks but pilot Flame does not light?**

No gas to fire, check isolating valves are open.  
Pipe work blockage, clean out.  
Air not fully purged, re-purge supply or wait longer.  
Spark earthen to metal work, reset gap correctly.  
Blocked pilot, clean out internally.

### **A pilot light but then goes out before main burner lights?**

Severe restriction in gas supply, clear obstruction.  
Faulty thermocouple, replace pilot unit.  
Hold control knob in for longer.  
Run through lighting system on the remote control several times allowing the valve to rest each time.

### **Fire does not spark at pilot?**

HT lead detached, refit.  
Spark gap too large or small reset correctly.  
Spark shorting to metalwork under tray, re-align HT lead

### **Fire runs for a time and then cuts off?**

Excessive room draught or flue pull, rectify.  
Loose or faulty thermocouple, rectify.  
O.D.S system in operation.  
Firebox grommet seal not fitted, rectify.  
Lint in pilot aeration hole, clean thoroughly internally

### **Pilot flame shrinks when fire is on high?**

Poor gas flow to fire, check pressure with fire on high.  
If pressure is low, remove any restriction in pipe work or valve.  
Check all isolators are adequately sized and fully open.  
Check meter pressure is adequate.  
Air leak under base of firebox, rectify.  
Lint in pilot aeration hole, clean thoroughly internally.  
Firebox grommet seal missing, rectify

### **Fire smells when first lit or in use?**

Newness smell from brand new appliance.  
Spillage occurring, call installer to carry out spillage test and rectify any problems.  
Low temperature sealants or combustible materials used in incorrect positions.  
Air leak under base of firebox, rectify  
Firebox grommet seal missing rectify.

## SECTION 18: USER INSTRUCTIONS

### IMPORTANT NOTES

The installation of this fire **MUST** only be carried out by a competent person (such as a Gas Safe registered fitter) in accordance with the Gas Safety (Installation and Use) Regulations 1998, the relevant British Standards, Codes of Practice, the Building Regulations and the manufacturers' instructions.

- Failure to comply with the above recommendations could lead to prosecution and invalidate the appliance warranty.
- Please ensure you are handed all of the manufacturer's documents on completion of the installation. This will include these instructions.
- Always keep a note of the installer's name and address, the original purchase receipt and the date of installation for future reference.
- The fire and flue should be serviced regularly to ensure continued safe operation.
- See the servicing section for further details.
- Frequency of service will depend on use, but **MUST** be carried out at least once annually.
- Parts of this appliance become naturally hot during use.
- It is recommended that a suitable fire guard conforming to BS 6778 is used, especially where young children, the elderly, or infirm are concerned.
- Combustible items, such as flooring and furniture, and soft wall coverings (such as blown vinyl or embossed paper) may discolour if fitted too close to the fire.
- See relevant section for further details on clearances to combustibles.
- No combustible material or flooring should protrude onto the hearth.
- **DO NOT** burn any foreign material on this fire, the coals must be of the correct type and lay out in accordance with the relevant section of these instructions.
- Failure to do so could create a hazard or lead to sooting.
- Before the appliance is installed, the chimney should be swept.
- All flues should be checked by the installer to ensure there are no defects or obstructions that may prevent the flow of combustion products.
- The fire is only suitable for use with the gas type for which it is supplied.
- This fire is supplied with a particular style of fire front/fret.
- Use of the fire front/fret will ensure an adequate airflow under the fire bed for the correct functioning of this appliance.
- Compliance with safety standards cannot be guaranteed if another style of front is used.
- A combustible shelf may be fixed to the wall above the fire, providing that it complies with the dimensions given in section 3 site requirements.
- No purpose provided ventilation is normally required for this appliance.
- The requirements of other appliances operating in the same space or room, and the results of a spillage test must be taken into consideration when assessing ventilation requirements; this will have been carried out by your Gas Safe registered installer.

***For Republic of Ireland, ventilation may be required, see IS 813, ICP3, IS 327, and any other rules in for***

## SECTION 18.1: OPERATING THE APPLIANCE

For your safety, the fire is fitted with a Flame Supervision Device (FSD), which will shut off the Gas supply if for any reason the pilot is extinguished.

This device incorporates a fixed probe, which senses heat from the pilot burner flame, if the probe is cooled, the device will prevent any gas flow.

If for any reason the flames go out or if the fire has been turned off for any reason, always **WAIT FOR 3 MINUTES** before attempting to re-light.

The pilot is visible through the Fuel bed at the front of the fire; rotate the coals for good viewing.

Push in and turn the control knob to the SPARK position, and hold there for a few seconds. Continue turning anti-clockwise through the spark click to the PILOT light position, ensuring that the control knob is depressed and the pilot has lit. If not, return the knob clockwise, and repeat.

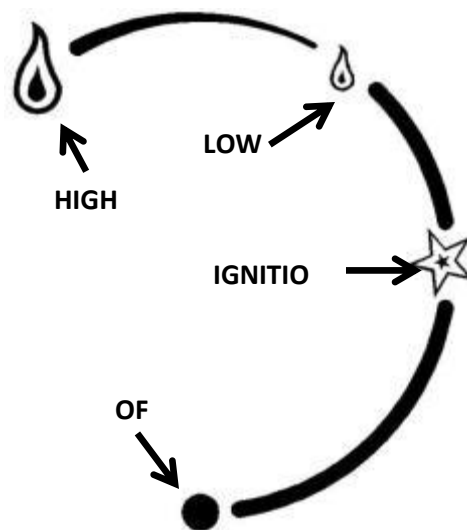

- When the pilot lights after the spark, keep the knob depressed for approximately ten to fifteen seconds.
- Now release the knob and the pilot should stay alight.
- If the pilot is extinguished during use, wait three minutes before repeating the ignition procedure.
- To achieve the HIGH setting, push the control knob in slightly and continue turning anti-clockwise to the high position.
- The main burner should light after a few seconds, to decrease the setting to LOW, turn the control knob clockwise to the low setting.
- To turn to the PILOT position from the HIGH or LOW positions, press the control knob in, and return to the pilot position and release.
- To turn the fire OFF, keep the control knob depressed, and return to the off position, then release.

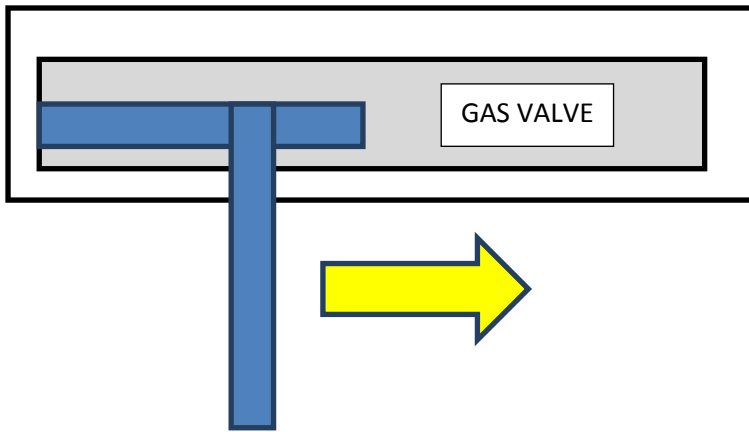

**STEP 1:**

From the standing position push the thumb control all the way to the RIGHT where a spark will be heard and pilot light will be generated, hold down for approximately 15 seconds.

**STEP 2:**

Release the pressure and the pilot light should now be established (if this fails repeat step 1 and hold down for 20 seconds).

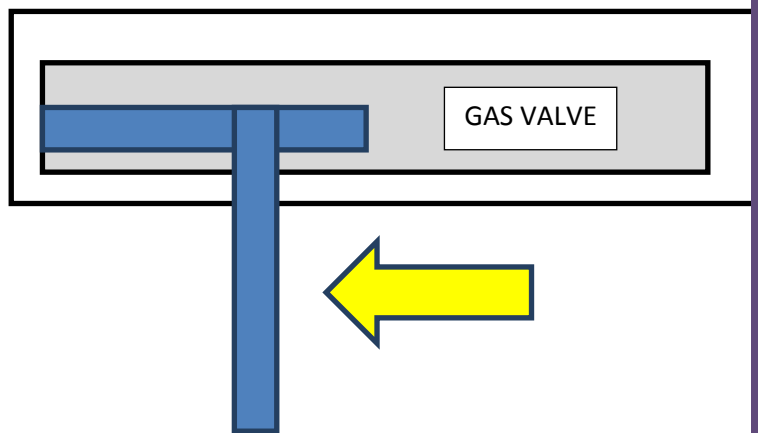

**STEP 3:**

Slide the control LEFT to increase the flame to the desired effect.

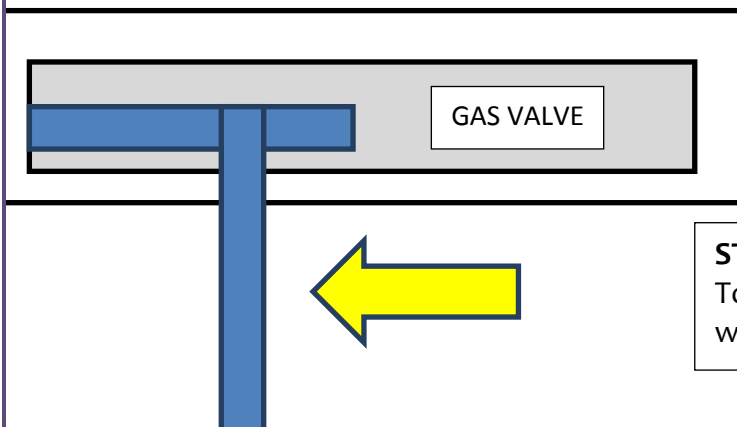

**STEP 4:**

To turn the appliance off simply push all the way to the LEFT, passed the positive stop.

## GENERAL CLEANING

- Before carrying out any of the following operations, ensure that the fire is OFF and completely cold.
- Debris that may form on the fire bed should be periodically removed by a competent person. Large deposits could indicate deterioration of the flue. This should be repaired by a competent person, and the fire serviced before further use.
- FIRE FRONT/FRET - Any dust accumulating in the fire front may be removed using a vacuum cleaner or dry cloth. Heavy stains may be removed by using a damp cloth and mild household detergent.
- Brass parts of the fire front may be cleaned using a suitable brass cleaner.
- Replace the front centrally against the fire after cleaning.
- PAINTED AREAS - These can be cleaned using a dry cloth.
- GLASS - Remove the Glass panel as per the installation instruction and clean glass with a glass cleaner and a lint free cloth or Microsoft cloth, if white haze or carbon discolouration is still apparent the a metal polish such as Hotspot or Peek can be used to remove these stubborn particles.

## SECTION 19: LIST OF SPARES

Code	SPARE PART DESCRIPTION	PART NUMBER						
	<u>CERAMICS</u>							
1A	FRONT MATRIX BLACK HEFD	PRT	CER	MX/F	HEFD	1	BLK	
2A	REAR MATRIX BLACK HEFD	PRT	CER	MX/RE	HEFD	1	BLK	
3A	COAL SET HEFD (17 PCS)	PRT	CER	CO	HEFD	1	BLK	
4A	PEBBLE SET (mixed 17 pc)	PRT	CER	PB	HEFD	1	MIX	
5A	PEBBLE HEFD FRONT MATRIX	PRT	CER	MX/F/PE	HEFD	1	GRE	
6A	PEBBLE HEFD REAR MATRIX	PRT	CER	MX/RE/PE	HEFD	1	GRE	
7A	CERAMIC LINING SET	PRT	CER	LIN	HEFD	1	BLK	
	<u>FIXING KIT</u>	PRT	FIX	FK	HEFD	0	SI	0
	INSTALLATION & USER MANUAL ALL MODELS	PRT	DOC	IM	HEFD	0	SI	1M
	TRIM 3 PART BRASS	PRT	DCF	TR	ECO	3PR	SK	BR
	TRIM 3 PART CHROME	PRT	DCF	TR	ECO	3PR	SK	CH
	TRIM 3 PART BLACK	PRT	DCF	TR	ECO	3PR	SK	BL
	<u>MANUAL OPTION</u>							
B1	PILOT NG THERMACO NG OXP-PG-82-460	PRT	VAL	PI	RO	PL	SIT	1
B2	BURNER V4 (NATURAL GAS)	PRT	VAL	BR	HEFD	NG	SIR	0
B3	INJECTOR (NATURAL GAS)	PRT	VAL	IJ	HEFD	BRAY	360	NG
B4	4mm Pilot inlet tube	PRT	VAL	TU	HEFD	M	SI	PI
B5	8mm Gas Inlet tube	PRT	VAL	TU	HEFD	M	SI	INL
B6	GAS CONTROL VALVE V4-28A	PRT	VAL	CV	ST	0	SG	0
B7	8mm Burner pipe	PRT	VAL	TU	HEFD	UN	SI	BT
B8	ISOLATION/PRESSURE TEST POINT VALVE INC NUT & OLIVE	PRT	VAL	IS	UNI	0	PR	0
B9	CONTROL VALVE KNOB (PACK X 2)	PRT	VAL	KN	UNI	0	MUL	15
B10	ENGINE (MANUAL) EXCLUDING CERAMICS	PRT	INS	HEFD	N	M	E -	0
	<u>SLIDE CONTROL OPTION</u>							
1D	ENGINE (SLIDE) EXCLUDING CERAMICS	PRT	INS	HEFD	N	SL	E -	0
2D	SLIDE CONTROL MECHANISM ASSEMBLY C/W LINKAGE	PRT	VAL	SL	UN	MC	SI	1
3D	PILOT GAS TUBE 4MM complete with nuts & olives	PRT	VAL	TU	PI	SL	SI	HEFD
4D	GAS INLET TUBE 8MM complete with nuts & olives	PRT	VAL	TU	IN	SL	SI	HEFD
5D	PILOT NG THERMACO NG OXP-PG-82-460	PRT	VAL	PI	RO	PL	SIT	1
7D	GAS INLET TUBE 8MM C/W INLET ELBOW, NUTS & OLIVES	PRT	VAL	TU	IN	SL	SI	HEFD
8D	INJECTOR (NATURAL GAS)	PRT	VAL	IJ	HE4	BRAY	360	NG
9D	BURNER (NATURAL GAS) FOR SLIDE CONTROL	PRT	VAL	BR	HEFD	NG	SIR	1
10D	H T LEADS X3 for spark generator	PRT	VAL	SL	UN	NG	SI	1
11D	SPARK GENERATOR	PRT	VAL	SG	UN	NG	TC	1
13D	TEDDINGTON VALVE 3173/011	PRT	VAL	SL	UN	0	TED	1
14D	LINK PLATE	PRT	VAL	SL	UN	0	HS	1
15D	LINK ROLLER WHEEL	PRT	VAL	SL	UN	0	HS	2